

Falk™ Lifelign® Gear Couplings

Save Up Front Money and Increase  
Equipment Life

(English-Metric)



**REXNORD**

# Falk™ Lifelign® Gear Couplings Realize Life-Long Savings

## Initial Savings

Falk Lifelign couplings provide the economies budget-minded users seek, without sacrificing coupling quality or reliability.

## Superior Bore Capacities and Torque Ratings

The unmatched bore capacities and torque ratings of Falk Lifelign couplings often allow you to select a smaller sized coupling for a given application.

In fact, selections for T frame, 60 hertz electric motors result in a drop of one coupling size for half of the 28 motor frames available. The result: quality, reliability and performance with average savings of 15-20% over competitive offerings.

The smaller overall size also makes Lifelign couplings well suited for limited space applications that still require large bores and high torque loads.

## Ideal for Existing Applications

Half for half interchangeability allows you to add capacity and realize the advantages of Lifelign couplings on your existing applications and designs, as well.

What's more, Lifelign's larger hub diameter features more metal over the keyway versus other designs, providing greater reserve strength against hub fractures due to shock or impact loads.

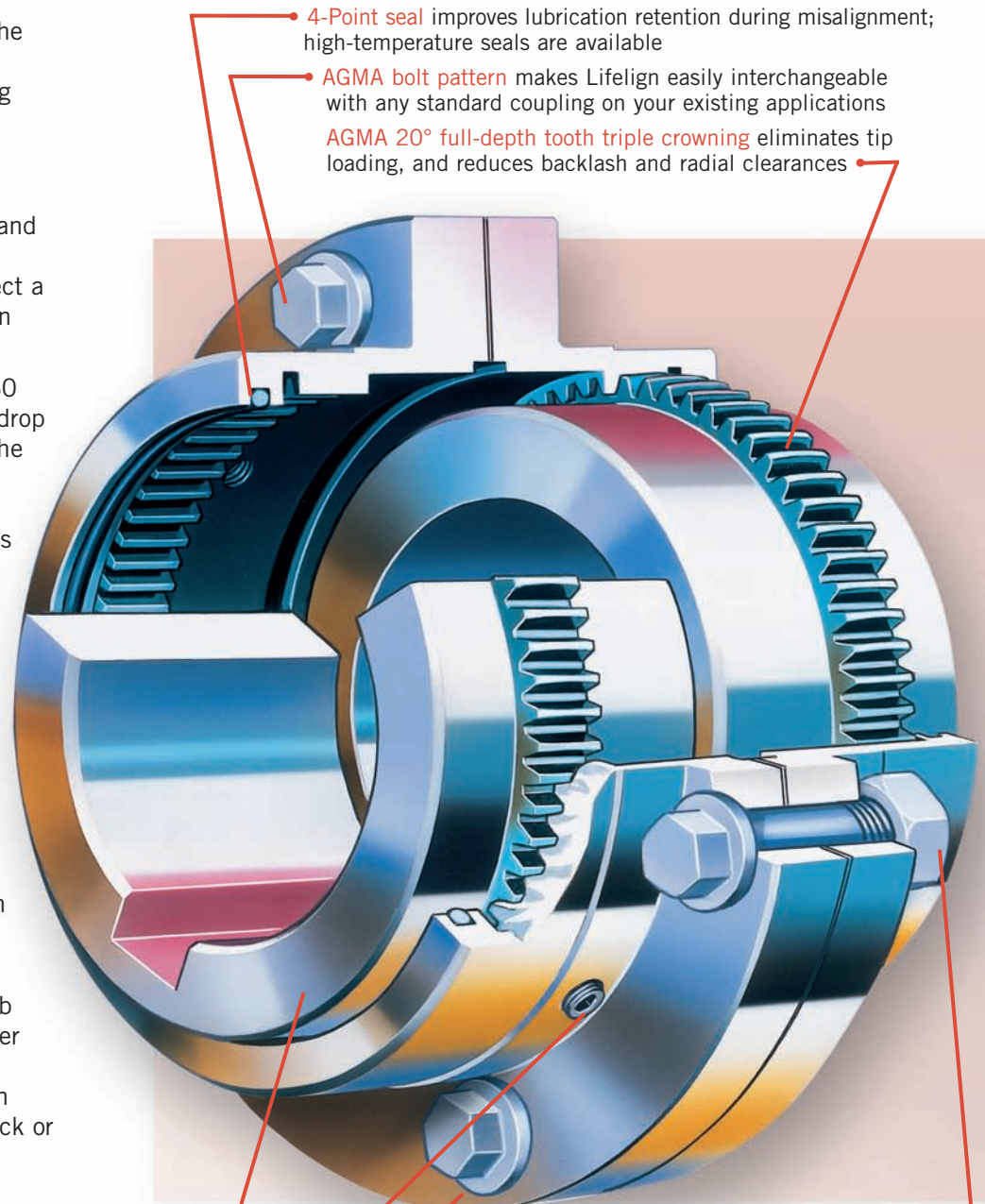

• **4-Point seal** improves lubrication retention during misalignment; high-temperature seals are available

• **AGMA bolt pattern** makes Lifelign easily interchangeable with any standard coupling on your existing applications

• **AGMA 20° full-depth tooth triple crowning** eliminates tip loading, and reduces backlash and radial clearances

• **High-strength Grade 8 Bolts** provide added protection against failure

• **Lube holes** located near the tooth mesh to ensure an adequate grease reservoir during initial startup

• **Massive Flex Hub** provides the industry's largest bore capacity for the most economical selection possible

• **Non-turning prevailing torque locknut** provides a reliable hold with fewer parts

### Greater Bore Capacity

AGMA Coupling Size	Popular Competitive Brands	Falk LIFELIGN Couplings
1	1.625	1.875
1 1/2	2.250	2.375
2	2.750	2.875
2 1/2	3.500	3.625
3	4.000	4.125
3 1/2	4.500	4.875
4	5.500	5.750
4 1/2	6.000	6.750
5	6.625	7.375
5 1/2	7.500	8.250
6	8.125	9.125
7	9.625	10.875

### Higher Torque Ratings

AGMA Coupling Size	Popular Competitive Brands	Falk LIFELIGN Couplings
1	7,500	10,080
1 1/2	18,900	20,790
2	31,500	37,800
2 1/2	56,700	66,150
3	94,500	107,100
3 1/2	151,200	163,800
4	220,500	270,900
4 1/2	302,400	371,700
5	434,700	500,900
5 1/2	573,300	655,200
6	749,700	800,100
7	1,008,000	1,197,000

### Designs to Meet a Diverse Range of Needs

#### G Standard Flanged Sleeve

General purpose series used on bulk handling systems, paper machines, fans, pumps, cranes mixers, sugar mills, crushers and many other high-torque applications.

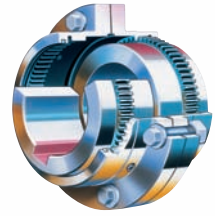

#### GC Continuous Sleeve

Used on high-speed equipment with low inertia requirements.

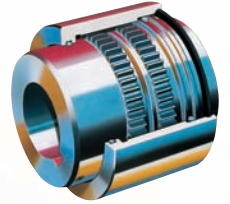

#### G Large Flanged Sleeve

For very high torque applications, including power plants, mining, cement, steel and metal mills, paper, sugar, rubber and other large industrial plants.

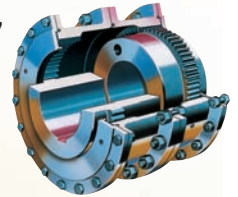

#### G10 Shrouded Bolt

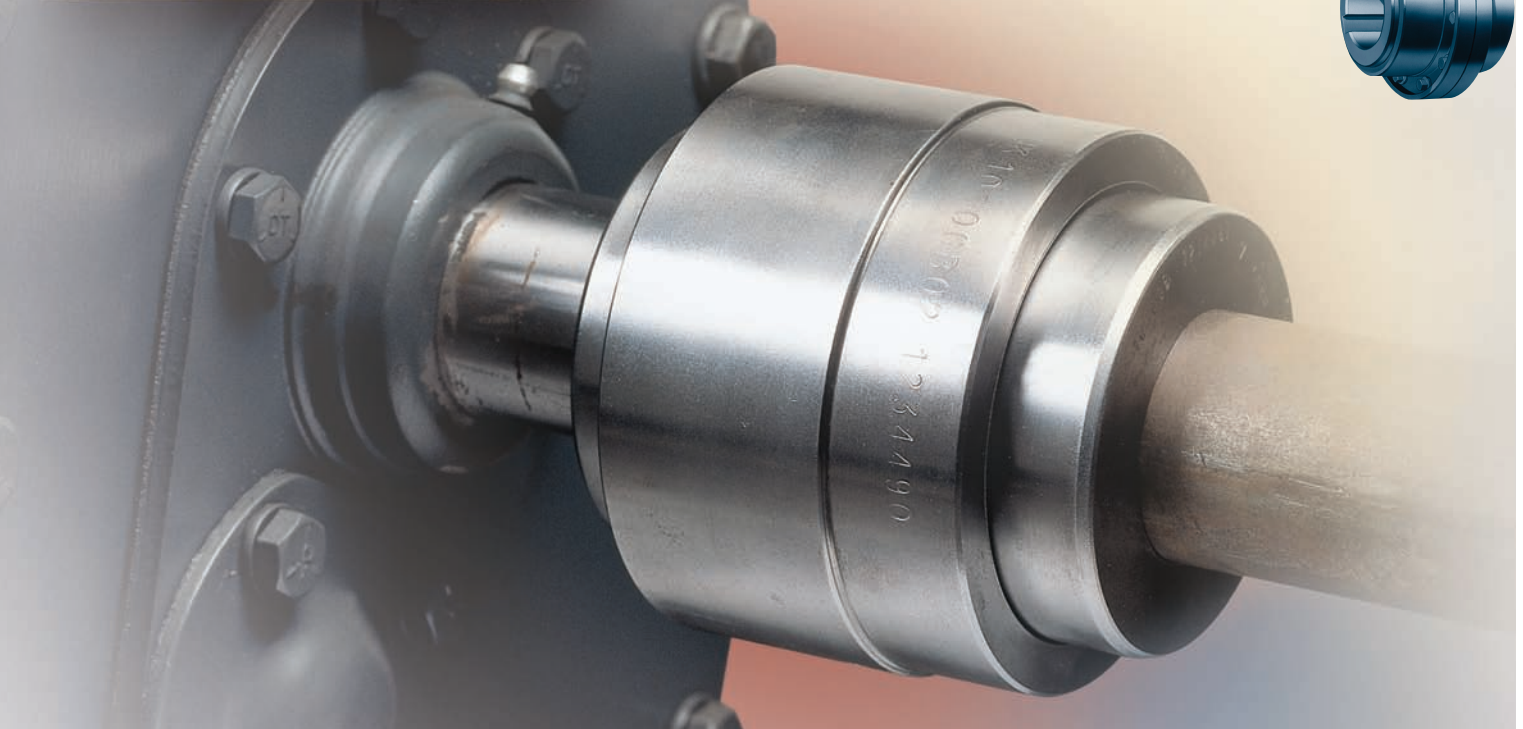
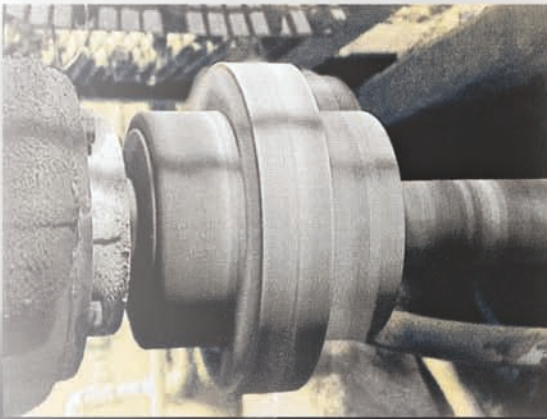

## Lifetime Savings

Lifesign Couplings are specially designed to remain your most economical solution by extending maintenance intervals, reducing wear and increasing service life.

## Advanced Lube System

Falk Long Term Grease (LTG) eliminates routine lubrication cycles for up to 3 years. The location of the lubrication hole in the sleeve ensures that an adequate grease reservoir will be maintained close to the gear mesh. Plus, Lifesign's 4-point seal contact provides better retention of lubricant, eliminating the axial seal movement that can draw lubricant out of the coupling should misalignment occur.

For added reliability our standard seals handle a maximum continuous operating temperature of 250°F (121°C) and a maximum intermittent temperature of 300°F (149°C). High temperature seals are available, extending maximum temperatures to 400°F (204°C) for continuous duty and 500°F (260°C) for intermittent use.

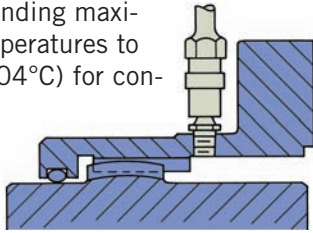

## Triple crown protection

Crowning at the root, tip and face of each tooth helps minimize wear damage due to misalignment. This triple-crown effect eliminates tip loading, while also reducing backlash and radial clearances.

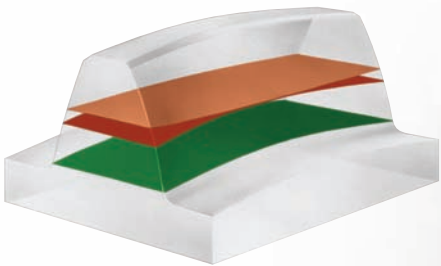

## Reliable, convenient fasteners

High-strength, Grade-8 fasteners provide added protection against coupling failure at the flange joint. To assure the easiest possible assembly and disassembly, fasteners are zinc-coated to prevent corrosion and feature non-turning locknuts, which allow one-wrench installation with no washers required.

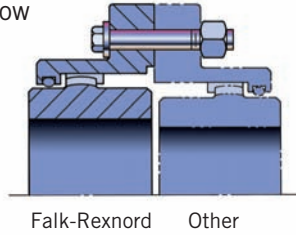

## You Get More than Cost Savings with Falk Lifesign Couplings

### Capacity

Rexnord supplies the largest gear couplings in the world for low-speed, high-torque applications or where bore capacities of 10" to 52" are required.

### Quality

Rexnord pours its own castings and completely machines the components to assure maximum product integrity with minimum lead times.

### Performance

Rexnord can supply alloy steels for hydraulic hub removal, increased wear resistance, or to increase torque ratings by an average of 60% for only about a 30% increase in price. The torque boost can allow smaller sizes to be used, thus significantly reducing overall costs.

## Selection

Rexnord supplies a complete range of coupling designs including, gear disc, grid, elastomer, composite, and fluid couplings.

## Expertise

Rexnord's extensive applications engineering expertise combines with our comprehensive product offering to assure that you wind up with the best choice for the job.... and your preferred requirements.

## Packaged System Design

Rexnord's unmatched variety of gear drives and power transmission components allows us to develop complete packaged systems for your power transmission needs. In many cases, pre-packaged systems offer drop-in installation or replacement, minimizing installation time and costs.

## Global Availability and Support

Rexnord's has 900+ distributor locations and 300+ sales engineers, offering local availability on a global basis.

## 3-Year Heavy-Duty Warranty

Rexnord rewrote industry expectations by offering the first 3-Year Warranty, standard, on all "heavy-duty" products.

## Online Support

Rexnord online support includes spares information and pricing, service data, product literature, quoting tools and engineering artwork.

# Selection Guide M451-110, October 2006

## Table of Contents

Nomenclature	6
Available Types	7-9
How to Select	10-11
Quick Selection Method	12-13
Service Factors	14-15
How to Order	15

## CONTINUOUS SLEEVE GEAR COUPLINGS —

### Dimensions & Specifications

Type GC02 Double Engagement	16
Type GC05 Single Engagement	17
Type GC05 Floating Shaft	18

## STANDARD FLANGED SLEEVE GEAR COUPLINGS —

### Dimensions & Specifications

Type G20 Double Engagement	19
Type G32 Spacer	20
Type G52 Single Engagement	21
Type G52 Floating Shaft	22-23
Type GV20 Vertical Double Engagement	24
Type GV52 Vertical Single Engagement	25
Types G62/G66 Brakewheel, Straight Bores & G63 Disc Brake	26
Types G62 & G66 Brakewheel, Taper Bores	27
Type GL20 Slide Double Engagement	28
Type GL52 Slide Single Engagement	29
Type G70 Disconnect, Inching Drives	30
Type G72 Disconnect	31
Type GP20/52/82 Insulated	32
Type G82 Rigid	33
Type GV82 Rigid Thrust	34
Type GR20 Shear Pin	35
Type G Mill Motor & Taper Bores	36

## Engineering Data

Recommended Commercial Keys for Bores With One Key	37
Shaft Diameters & Ratings for NEMA 60 Hertz & 50 Hertz	
Metric Motors	37
Maximum Bores	38
Recommended Bore Tolerances, Falk Steel Coupling Hubs	38
Flanged Sleeve & Rigid Hub Details	39
Puller Bolt Holes	39
Torsional Stiffness	40
WR <sup>2</sup> Values	40
Standard Filleted Keyways & Chamfered Keys	40
Variable Gap	41
Misalignment Capacity	41

## LARGE FLANGED SLEEVE GEAR COUPLINGS —

### Dimensions & Specifications

Type G20 Double Engagement	42
Type G52 Single Engagement	43
Type G52 Floating Shaft	44
Type GV20 Vertical Double Engagement	45
Type GV52 Vertical Single Engagement	46
Type GL20-4 Slide Double Engagement	47
Type G70 Disconnect, Inching Drives	48
Type G82 Rigid	49
Type GR20 Shear Pin	50

## Engineering Data

Recommended Commercial Keys for Bores with One Key	51
Recommended Bore Tolerances, Falk Steel Coupling Hubs	51
Flanged Sleeve & Rigid Hub Details	52
Sleeve Jack Bolt Holes	52
Puller Bolt Holes	52
Torsional Stiffness	52
WR <sup>2</sup> Values	52
Bore Ranges for Reduced Shank Dia. Hubs	53
Puller Bolt Holes for Reduced Shank Dia. Hubs	53
Standard Filleted Keyways & Chamfered Keys	54
Misalignment Capacity	55

## ALL TYPES

Recommended Hub Bores for Interference & Clearance Fit	56-57
Interchange Guide Flanged & Continuous Sleeve	58-59
Coupling Application Data Sheet	60



**Factory Warranty** We're so confident in the performance and reliability of our latest generation of Falk gear drives that we're backing this comprehensive offering with the best standard warranty in the business. Our full, 3-year Heavy-Duty Warranty provides "shaft-to-shaft" protection on all Falk components – including bearings and seals. It's an industry first... and one more powerful reason why Rexnord is your ultimate bottom-line drive and coupling value.★

★ Warranty extends for 3 years from date of shipment.

## Basic Information

Install and operate Rexnord products in conformance with applicable local and national safety codes and per Rexnord installation manuals which are available upon request. Suitable guards for rotating members may be purchased from Rexnord as optional accessories. Consult your local Rexnord representative for complete details.

**WARNING:** Lock out power and remove all external loads from the system before attempting to service any component in the system. Locking out the power and removing the load will reduce the possibility of unexpected motion or reaction in the system.

Falk Long Term Grease Benefits include: Increased coupling life, significantly extended re-lubrication intervals, reduced maintenance costs, reduced downtime, superior lubrication, high load carrying capabilities and it is usable up to 121°C (250°F).

For information on Falk Long Term Grease, request Form 840201. Lifalign gear couplings are warranted for 3 years when lubricated with Falk LTG Long Term Grease.

Copyright 2004, 2006, Rexnord Industries, LLC. All Rights Reserved. Litho in U.S.A. FALK, A-PLUS, LIFELIGN, OMNIBOX, RAM, RENEW, STEELFLEX, and ULTRAMITE are registered trademarks.

Magnum Seal is a trademark of The Falk Corporation for its rotary shaft sealing system for enclosed gear drives.

Taper-Lock is a registered trademark of a bushing under license.

Viton is a registered trademark of the DuPont Co.

The contents of this selection guide are subject to change without notice or obligation. Information contained herein should be confirmed before placing orders.

# Lifeline® Gear Coupling Nomenclature

Type GC (Pages 16 thru 18 & 38 thru 41)

1010

SIZE

GC

PRODUCT  
CLASSIFICATION

02

TYPE

Gear — Continuous Sleeve

GC02 = Double Engagement  
GC05 = Single Engagement/Floating Shaft

Type G (Pages 19 thru 41)

1010

SIZE

G

PRODUCT  
CLASSIFICATION

20

TYPE (Shrouded and Exposed Bolts)

Gear — Standard Flanged Sleeve

G10/20 = Double Engagement (Shrouded/Exposed)  
G51/52 = Single Engagement/Floating Shaft (Shrouded/Exposed)  
GV10/20 = Vertical Double Engagement (Shrouded/Exposed)  
GV51/52 = Vert. Single Engage./Floating Shaft (Shrouded/Exposed)  
G62 = Brakewheel Double Engagement (Exposed)  
G63 = Disc Brake Double Engagement (Exposed)  
G66 = Brakewheel Single Engagement (Exposed)  
GL20 = Slide Double Engagement (Exposed)  
GL52 = Slide Single Engagement/Floating Shaft (Exposed)  
G70 = Disconnect Inching Drives  
G72 = Disconnect (Exposed)  
G31/32 = Spacer (Shrouded/Exposed)  
GP20 = Insulated Double Engagement (Exposed)  
GP52 = Insulated Single Engagement/Floating Shaft (Exposed)  
GP82 = Insulated Rigid (Exposed)  
G81/82 = Rigid (Shrouded/Exposed)  
GV82 = Vertical Rigid (Exposed)  
GR20 = Shear Pin (Exposed)

Type G (Pages 42 thru 55)

1080

SIZE

G

PRODUCT  
CLASSIFICATION

20

TYPE (Exposed Bolts Only)

Gear — Large Flanged Sleeve

Type G20 = Double Engagement  
Type G52 = Single Engagement/Floating Shaft  
Type GV20 = Vertical Double Engagement  
Type GV52 = Vertical Single Engagement/Floating Shaft  
Type GL20 = Slide Double Engagement  
Type G70 = Disconnect/Inching Drives  
Type G32 = Spacer  
Type G82 = Rigid  
Type GV82 = Vertical Rigid  
Type GR20 = Shear Pin

---

# Lifeline Gear Coupling Types

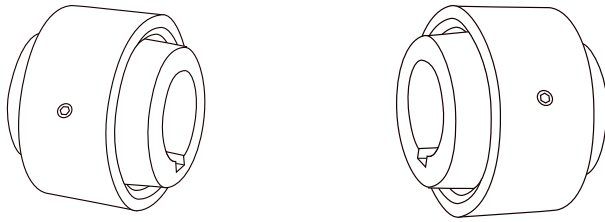

Type GC02 & GC05

With two hubs and one sleeve, the simplicity of this continuous sleeve coupling allows it to be easily adapted to a wide variety of applications. It's very compact, low in rotating mass, and has a lower initial cost than flanged types. (See Pages 16 & 17.)

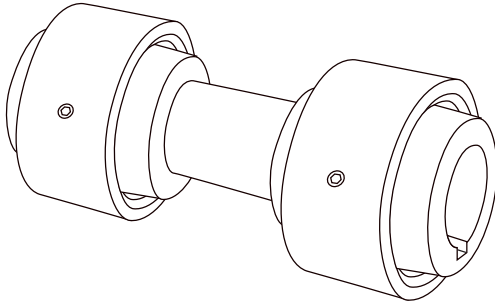

Type GC05 Floating Shaft

Floating shaft assemblies are used when distance between equipment is too great for spacer couplings. A standard floating shaft assembly consists of two standard single engagement couplings and a connecting shaft. A floating shaft can eliminate the need for additional bearing supports along spanning shafts because the shaft is supported by connected equipment through the single engagement couplings. (See Page 18.)

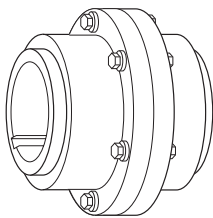

Types G20 & GV20

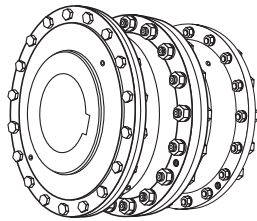

Type G Large Gear Coupling

The Type G20 double engagement, close coupled type has two flex halves to accommodate both offset and angular misalignment or a combination of the two, as well as end float. It is ideal for all horizontal, close coupled applications including fans, overhead cranes, conveyors, steel and paper mill equipment. It is adaptable with limited end float kits for use on electric motors, generators or any machines fitted with sleeve or straight roller bearings. (See Page 19.)

Type GV20 vertical double engagement gear coupling is a standard horizontal double engagement gear coupling modified to accommodate the sleeve centering assembly. Recommended for inclinations over 10°. (See Pages 24 and 45.)

The Type G Large Gear Coupling is available in all types for capacities up to 8,185,000 Nm, (72,450,00 lb-in. (See Page 42.)

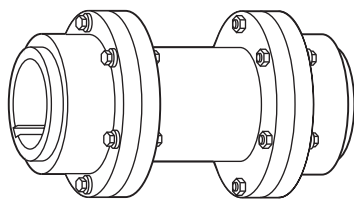

Type G32

Spacer couplings for pump and compressor applications simplify servicing connected equipment. Spacer couplings use a standard double engagement coupling with a spacer tube and an additional set of fasteners. Stock spacer lengths for quick delivery are available in the popular sizes. Special lengths are also available. (See Page 20.)

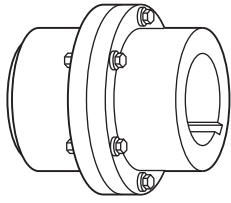

Types G52 & GV52

The Type G52 single engagement design is used with floating shafts or three bearing drive trains. It has one flex half and one rigid half and only accepts angular misalignment. (See Pages 21 and 43.)

The GV52 vertical single engagement gear coupling is a standard horizontal single engagement gear coupling modified to accommodate the sleeve centering assembly. It is recommended for inclinations over 10°. Downward thrust capacity for Sizes 1010 thru 1030GV52 is 1 130 Nm; Sizes 1035 thru 1070GV52 is 3 390 Nm and Sizes 1080GV52 and larger is 9 830 Nm. (See Pages 25 & 46.)

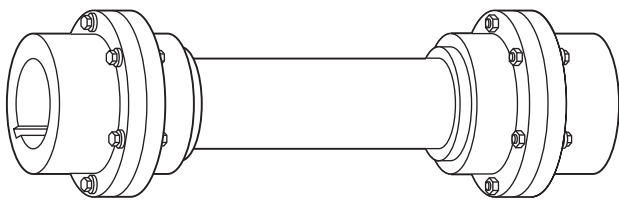

Types G52 & GV52 Floating Shaft

Floating shaft assemblies are used when distance between equipment is too great for spacer couplings. A standard floating shaft assembly consists of two standard single engagement couplings, two gap discs and a connecting shaft. A floating shaft can eliminate the need for additional bearing supports along spanning shafts because the shaft is supported by connected equipment through the single engagement couplings. (See Pages 22 and 44.) When used with a vertical floating shaft on inclinations over 10°, the Type GV52 coupling is used as the lower coupling to support the shaft. (See Pages 25 and 46.)

Flex Hubs on Floating Shaft (RFFR) — Assembly of the flex hubs on the floating shaft allows for easier replacement and allows the rigid hubs with greater bore capacity to be used on the connected equipment shafts. This frequently means a smaller coupling size can be utilized.

Rigid Hubs on Floating Shaft (FRRF) — When the rigid hubs are on the floating shaft, shorter shaft spans can be accommodated, since no cover drawback is required.

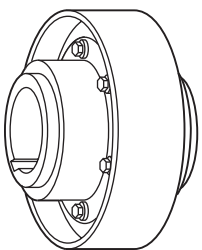

Types G62 & 66

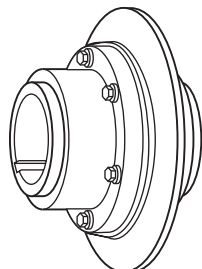

Type G63

Double or single engagement brakewheel and disc brake couplings are used for applications, such as cranes, hoists and conveyors. Brakewheel and disc brake couplings accommodate misalignment between connected equipment and eliminate the need for double shaft extensions on motors and gear drives for applications requiring brakes. (See Pages 26 & 27.)

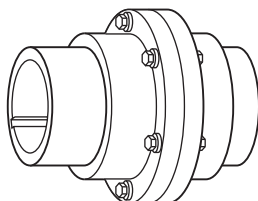

Types GL20 & GL52

Double and single engagement Slide couplings are used for applications requiring axial movement to accommodate thermal shaft expansion or adjustment. (See Pages 28, 29, and 47.)



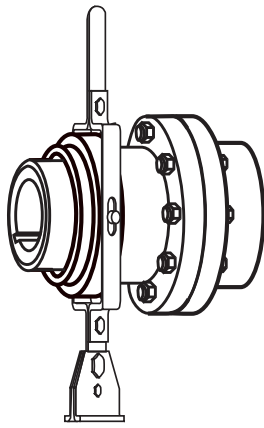

Types G70 & G72

Type G70 Disconnect couplings are used for low speed applications that require quick disconnect of equipment or inching drives. It is used for occasional servicing or inspection of drive system components and is most commonly used on portable or stationary inching drive systems where the driving end hub/sleeve combination is mounted on the driving shaft on the incher for connecting or disconnecting at standstill. (See Pages 30 and 48.)

Type G72 Disconnect couplings were designed for higher speed applications that require quick disconnect such as backup drives. When the long flex hub is mounted on the auxiliary driving shaft, the changeover is performed at standstill by engaging the free running hub. (See Page 31.)

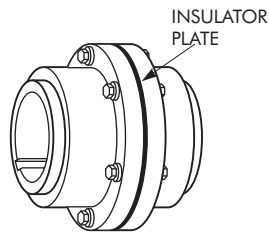

Types GP20, GP52 & GP82

Double, single or rigid engagement insulated couplings are used to eliminate the flow of stray current from one shaft to another and to protect sensitive electrical equipment. They are not intended to withstand high potential currents, short circuits or static charges. Insulated couplings consist of standard hubs and sleeves, and utilize reduced diameter socket head cap screws. The insulator plate is made of a NEMA Grade LE phenolic material and insulator bushings and washers are made of NEMA Grade G9 phenolic material. (See Page 32.)

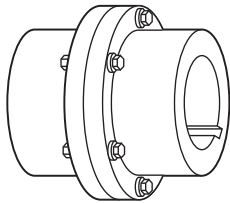

Type G82

Rigid couplings are used when there is no need to accommodate misalignment, and where thrust loads are generated such as vertical mixer applications. (See Pages 33, 34, and 49.)

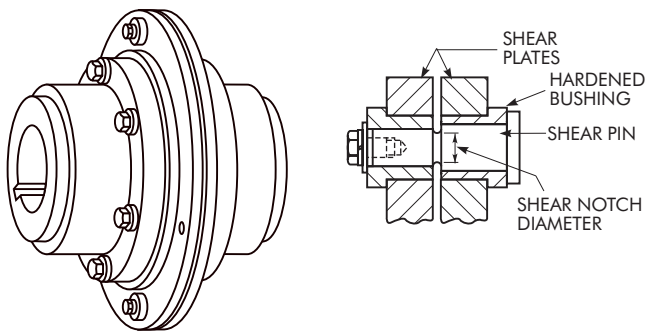

Type GR20

Shear pin couplings are used for applications subject to jamming and overload. When pins break, the equipment is physically disconnected preventing damage. If desired shear settings are unknown, the selection should be referred to the Factory. (See Pages 35 and 50.)

# How to Select

## Standard Selection Method

The standard selection method can be used for most motor, turbine, or engine driven applications. The following information is required to select a gear coupling.

- Kilowatt (kW) or torque (Nm)
- Running rpm.
- Application or type of equipment to be connected (motor to pump, drive to conveyor, etc.).
- Shaft diameters.
- Shaft gaps.
- Physical space limitations
- Special bore or finish information and type of fit

**Exceptions are High Peak Loads, Brake Applications or high frequency axial sliding (greater than 5 per hour). For these conditions, use the Formula Selection Method on the next page. Applications that require rapid changes in direction or torque reversals should be referred to Falk.**

1. **RATING:** Determine system torque. If torque is not given, calculate as shown below.

$$\text{System Torque (Nm)} = \frac{\text{kW} \times 9549}{\text{rpm}}$$

Where: kW (Kilowatt) is the actual or transmitted power required by the application (if unknown, use the motor or turbine nameplate rating) and rpm is the actual speed the coupling is rotating.

2. **SERVICE FACTOR:** Determine the appropriate service factor from Tables 4 and 5, Page 14, or Table 6, Page 15.

3. **REQUIRED MINIMUM COUPLING RATING:** Determine the required minimum coupling rating as shown below

$$\text{Minimum Coupling Rating} = \text{S.F. (Service Factor)} \times \text{Torque (Nm)}$$

4. **TYPE:** Refer to Pages 7-9 and select the appropriate coupling type.

5. **SIZE:** Determine proper size of type selected from Table 1 by tracing down torque column to a value that is equal or greater than that determined in Step 3 above. Then turn to the dimension pages of appropriate coupling type selected and check the following for the size selected.

6. **Check:** Coupling Capacities and Dimensions

- Bores** — Check shaft diameters against coupling maximum bore. If bore is inadequate, consider the use of a reduced key from engineering tables, or select a larger size coupling.
- Speeds (rpm)** — Check the operating rpm against the coupling allowable speed. If catalogued values are inadequate, consider balancing. Balancing may allow up to 50% increase in speeds shown. Contact the Factory with complete application details.
- Dimensions** — Checks are: length of hubs and alignment clearances against shaft lengths, outside diameter of coupling against radial clearances

### STANDARD SELECTION EXAMPLE:

Select a gear coupling to connect a 350 kW 1000 rpm electric motor to a drive high speed shaft of a maneuvering winch. Maximum shaft separation is 6 mm. Motor shaft diameter is 85 mm and key is 22 mm x 14 mm. Winch shaft diameter is 75 mm and key is 20 mm x 12 mm. Motor and winch extensions are both 150 mm long.

#### 1. DETERMINE REQUIRED RATING:

$$\text{System Torque (Nm)} = \frac{350 \text{ kW} \times 9549}{1000 \text{ rpm}} = 3342$$

2. **SERVICE FACTOR:** From Service Factor Table 4, Page 14 = 1.5

#### 3. REQUIRED MINIMUM COUPLING RATING:

$$1.5 \times 3342 \text{ Nm} = 5013 \text{ Nm}$$

4. **TYPE:** From Page 7, to connect close coupled shafts (6 mm gap) the double engagement Type 1025GC02 or Type 1025G20 coupling is the selection. Refer to Pages 14 or 17 for dimensions.

5. **SIZE:** From Page 16, a Size 1025GC02 or Page 19, a Size 1025G20 is the proper selection based on a torque rating of 7 470 Nm exceeding the required minimum coupling rating of 5013 Nm.

6. **CHECK:** Maximum speed capacity of 3,330 (1025GC02) and 5000 (1025G20) rpm exceeds required speed of 1000 rpm. Maximum bore capacity of 98 mm exceeds the actual shaft diameters.

**TABLE 1 — Torque and Horsepower Ratings**

Coupling Size		Torque Rating (Nm)		kW per 100 RPM	
1010G/GC		1 140		11,9	
1015G/GC		2 350		24,6	
1020G/GC		4 270		44,7	
1025G/GC		7 470		78,3	
1030G/GC		12 100		127	
1035G/GC		18 500		194	
1040G		30 600		321	
1045G		42 000		440	
1050G		56 600		593	
1055G		74 000		775	
1060G		90 400		947	
1070G		135 000		1 420	
Coupling		Torque Rating (Nm) x10 <sup>3</sup>		kW per 100 RPM	
		1000 Series	2000 Series	1000 Series	2000 Series
1080G	2080G	170	234	1 780	2 450
1090G	2090G	226	315	2 360	3 300
1100G	2100G	310	443	3 250	4 640
1110G	2110G	413	609	4 320	6 380
1120G	2120G	555	777	5 810	8 140
1130G	2130G	719	925	7 530	9 690
1140G	2140G	911	1 140	9 540	11 900
1150G	2150G	1 100	1 350	11 500	14 200
1160G	2160G	1 310	1 640	13 700	17 100
1180G	2180G	1 660	2 140	17 400	22 400
1200G	2200G	2 140	2 850	22 400	29 800
1220G	2220G	2 720	3 560	28 500	37 300
1240G	2240G	3 470	4 480	36 400	47 000
1260G	2260G	4 490	5 480	47 000	57 400
1280G	2280G	5 840	6 760	61 100	70 800
1300G	2300G	6 760	8 190	70 800	85 700

# How to Select

## Formula Selection Method

The Standard Selection Method can be used for most coupling selections. The procedure below should be used for:

- High Peak Loads
- Brake Applications (where the disc brake or brakewheel is to be an integral part of the coupling, consult the Factory for design options.)
- High Frequency Axial Sliding
- Shear Pin Couplings

Providing system peak torque and frequency, duty cycle, and brake torque rating will allow for a more refined selection using the Formula Selection Method.

- 1. High Peak Loads:** Use one of the following formulas for applications using motors, with torque characteristics that are higher than normal; applications with intermittent operations, shock loading, inertia effects due to starting and stopping and or system induced repetitive high peak torques. System Peak Torque is the maximum torque that can exist in the system. Select a coupling with a torque rating equal to or greater than selection torque calculated below.

### A. NON-REVERSING HIGH PEAK TORQUE

Selection Torque (Nm) = System Peak Torque

or

$$\text{Selection Torque (Nm)} = \frac{\text{System Peak kW} \times 9549}{\text{rpm}}$$

### B. REVERSING HIGH PEAK TORQUE

Selection Torque (Nm) = 1.5 x System Peak Torque

or

$$\text{Selection Torque (Nm)} = \frac{1.5 \times \text{Peak kW} \times 9549}{\text{rpm}}$$

C. OCCASIONAL PEAK TORQUES (Non-Reversing) — If a system peak torque occurs less than 1000 times during the expected coupling life, use the following formula:

Selection Torque (Nm) = .5 x System Peak Torque

or

$$\text{Selection Torque (Nm)} = \frac{.5 \times \text{Peak kW} \times 9549}{\text{rpm}}$$

For reversing service, select per Step B, above.

- 2. BRAKE APPLICATIONS:** If the torque rating of the brake exceeds the motor torque, use the brake rating as follows:

Selection Torque (Nm) = Brake Torque Rating x S.F.

- 3. HIGH FREQUENCY AXIAL SLIDING:** For Type GL couplings; if axial movement occurs more than 5 times per hour, add .25 to the service factor.

$$\text{Selection Torque} = \frac{\text{kW} \times 9549 \times (\text{S.F.} + .25)}{\text{rpm}}$$

- 4. SHEAR PIN COUPLINGS:** When selecting Type GR couplings, make certain that the required shear torque is within the minimum/maximum range for the coupling size selected. Refer to Pages 35 and 50.

The user provided shear torque value must be based on a system analysis. It is recommended that the shear torque value be at least 225% of the normal transmitted torque value for non-reversing applications to avoid breaking the shear pins due to fatigue during motor start-up. For reversing applications, the recommended shear torque setting is 300-400% of normal torque to avoid fatigue failures. If the connected equipment cannot tolerate these torque levels, expect to replace the shear pins more frequently.

### FORMULA SELECTION EXAMPLE — High Peak Load:

Select a gear coupling to connect a gear drive low speed shaft to a reversing runout mill table. The electric motor rating is 37 kW at its base speed and the system peak torque at the coupling is estimated to be 17 000 Nm. The coupling speed is 77 rpm at the motor base speed. Drive shaft diameter is 100 mm and key is 28 mm x 16 mm. Runout table roll diameter is 135 mm and key is 36 mm x 20 mm. Shaft separation is 12 mm maximum. Motor and drive shaft extensions are both 180 mm long.

- 1. TYPE:** From Page 7, to connect close coupled shafts (12 mm gap), the double engagement Type G20 coupling is the selection.

### 2. REQUIRED MINIMUM COUPLING RATING:

Use the Reversing High Peak Torque formula in Step 1B.

$$1.5 \times 17\,000 \text{ Nm} = 25\,500 \text{ Selection Torque}$$

- 3. SIZE:** From Table 1, Size 1040G20 coupling with torque rating of 30 600 exceeds the selection torque of 25 500 Nm
- 4. CHECK:** The maximum bore of 160 mm, Table 13, Page 38, allowable speed of 3600 rpm and Dimension M of 145 mm, on Page 17, meet the requirements.

# Quick Selection Method

## 1. SELECT COUPLING TYPE

The Type G20 coupling is the proper selection for most industrial applications. For quick disconnect couplings, especially suited for pump applications, consider the Type G32 spacer coupling. If an application requires a special purpose coupling, refer application details to the local Rexnord Representative.

## 2. DETERMINE SERVICE FACTOR

A. For MOTOR, TURBINE, or ENGINE driven applications, refer to Tables 4 and 5 on Page 14.

B. For BRAKE, HIGH PEAK LOAD, and Type GL slide coupling applications, refer to Formula Method on Page 11.

## 3. DETERMINE EQUIVALENT HORSEPOWER

Refer to Table 2 below. Under the actual motor kW required and opposite the service factor determined in Step 2, read the equivalent kW.

## 4. DETERMINE COUPLING SIZE

A. Refer to Table 3 below. Trace horizontally from the required speed to a value equal to or larger than the equivalent Kilowatts determined in Step 3. Read the coupling size at top of column.

B. Check shaft diameters against coupling maximum bores. If a larger bore is required, select a larger coupling.

**TABLE 2 — Equivalent Power = (Actual kW x Service Factor)**

Service Factor †	Actual kW																														
	0.25	0.37	0.55	0.75	1.1	1.5	2.2	3	4	5.5	7.5	9.2	11	15	18.5	22	30	37	45	55	75	90	110	132	150	185	200	220	250	300	330
<b>1.00</b>	0.25	0.37	0.55	0.75	1.1	1.5	2.2	3	4	5.5	7.5	9.2	11	15	18.5	22	30	37	45	55	75	90	110	132	150	185	200	220	250	300	330
<b>1.25</b>	0.31	0.46	0.69	0.9	1.4	1.9	2.8	3.8	5	6.9	9.4	11.5	13.8	18.8	23.1	27.5	37.5	46.3	56.3	68.8	93.8	113	138	165	188	231	250	275	313	375	413
<b>1.50</b>	0.38	0.56	0.83	1.1	1.7	2.3	3.3	4.5	6.0	8.3	11.3	13.8	16.5	22.5	27.8	33.0	45.0	55.5	67.5	82.5	113	135	165	198	225	278	300	330	375	450	495
<b>1.75</b>	0.44	0.65	0.96	1.3	1.9	2.6	3.9	5.3	7.0	9.6	13.1	16.1	19.3	26.3	32.4	38.5	52.5	64.8	78.8	96.3	131	158	193	231	263	324	350	385	438	525	578
<b>2.00</b>	0.50	0.74	1.1	1.5	2.2	3.0	4.4	6.0	8.0	11.0	15.0	18.4	22.0	30.0	37.0	44.0	60.0	74.0	90.0	110	150	180	220	264	300	370	400	440	500	600	660
<b>2.50</b>	0.63	0.93	1.4	1.9	2.8	3.8	5.5	7.5	10	13.8	18.8	23.0	27.5	37.5	46.3	55.0	75.0	92.5	113	138	188	225	275	330	375	463	500	550	625	750	825
<b>3.00</b>	0.75	1.1	1.7	2.3	3.3	4.5	6.6	9.0	12	16.5	22.5	27.6	33.0	45.0	55.5	66.0	90.0	111	135	165	225	270	330	396	450	555	600	660	750	900	990
<b>3.50</b>	0.88	1.3	1.9	2.6	3.9	5.3	7.7	10.5	14	19.3	26.3	32.2	38.5	52.5	64.8	77.0	105	130	158	193	263	315	385	462	525	648	700	770	875	1050	1155

† For service factors not listed. Equivalent kW = Actual kW x Service Factor.

**TABLE 3 — Coupling Selection . . . Based on Equivalent kW Ratings**

	1010G	1015G	1020G	1025G	1030G	1035G	1040G	1045G	1050G	1055G	1060G	1070G
<b>Max Bore (G10/G20), mm</b>	50	65	78	98	111	134	160	183	200	220	244	289
<b>Max Speed (G10/G20)</b>	8 000	6 500	5 600	5 000	4 400	3 900	3 600	3 200	2 900	2 650	2 450	2 150
<b>Torque (N-m)</b>	1 140	2 350	4 270	7 470	12 100	18 500	30 600	42 000	56 600	74 000	90 400	135 000
<b>kW / rpm</b>	0,119	0,246	0,447	0,783	1,27	1,94	3,21	4,40	5,93	7,75	9,47	14,2
RPM	kW Ratings											
<b>4500</b>	536	1110	2010	3520								
<b>3600</b>	428	886	1610	2820	4570	6980	11600					
<b>3000</b>	357	738	1340	2350	3810	5820	9630	13200				
<b>2500</b>	298	615	1120	1960	3180	4850	8030	11000	14800	19400		
<b>2100</b>	250	517	939	1640	2670	4070	6740	9240	12500	16300	19900	29800
<b>1800</b>	214	443	805	1410	2290	3490	5780	7920	10700	14000	17000	25600
<b>1750</b>	208	431	782	1370	2220	3400	5620	7700	10400	13600	16600	24900
<b>1450</b>	173	357	648	1140	1840	2810	4650	6380	8600	11200	13700	20600
<b>1170</b>	139	288	523	916	1490	2270	3760	5150	6940	9070	11100	16600
<b>1000</b>	119	246	447	783	1270	1940	3210	4400	5930	7750	9470	14200
<b>870</b>	104	214	389	681	1100	1690	2790	3830	5160	6740	8240	12400
<b>720</b>	85.7	177	322	564	914	1400	2310	3170	4270	5580	6820	10200
<b>650</b>	77.4	160	291	509	826	1260	2090	2860	3850	5040	6160	9230
<b>580</b>	69.0	143	259	454	737	1130	1860	2550	3440	4500	5490	8240
<b>520</b>	61.9	128	232	407	660	1010	1670	2290	3080	4030	4920	7380
<b>420</b>	50.0	103	188	329	533	815	1350	1850	2490	3260	3980	5960
<b>350</b>	41.7	86.1	156	274	445	679	1120	1540	2080	2710	3310	4970
<b>280</b>	33.3	68.9	125	219	356	543	899	1230	1660	2170	2650	3980
<b>230</b>	27.4	56.6	103	180	292	446	738	1010	1360	1780	2180	3270
<b>190</b>	22.6	46.7	84.9	149	241	369	610	836	1130	1470	1800	2700
<b>155</b>	18.4	38.1	69.3	121	197	301	498	682	919	1200	1470	2200
<b>125</b>	14.9	30.8	55.9	97.9	159	243	401	550	741	969	1180	1780
<b>100</b>	11.9	24.6	44.7	78.3	127	194	321	440	593	775	947	1420
<b>84</b>	10.0	20.7	37.5	65.8	107	163	270	370	498	651	795	1190

C. Check the required speed against the allowable speed of the coupling selected. If a higher speed is required, refer complete details to the local Rexnord Representative.

D. Check dimensions . . . Dimension M in particular.

**EXAMPLE:**

Select a gear coupling to connect the low speed shaft of a gear drive to a belt conveyor. The motor is 250 kW and the low speed shaft RPM is 68. The gear drive shaft is 160 mm and the conveyor shaft is 180 mm.

**SELECTION:**

1. To connect close coupled shafts and to accommodate anticipated shaft misalignment, the double engagement Type G20 coupling shown on Page 19, is the selection.
2. From Table 4 on Page 14, the service factor is 1.0.
3. From Table 2, Page 12, the equivalent power is 250 kW.
4. From Table 3 below, the coupling size is 1045G for 68 rpm. From the table on Page 19, the maximum bore of 183 mm, and allowable speed of 3200 rpm are all satisfactory. Check other dimensional information on Page 19 against the available shaft lengths, shaft gaps, and diameter restrictions.

**TABLE 3 — Coupling Selection . . . Based on Equivalent kW Ratings (Continued)**

	1010G	1015G	1020G	1025G	1030G	1035G	1040G	1045G	1050G	1055G	1060G	1070G
<b>Max Bore (G10/G20) mm</b>	<b>50</b>	<b>65</b>	<b>78</b>	<b>98</b>	<b>111</b>	<b>134</b>	<b>160</b>	<b>183</b>	<b>200</b>	<b>220</b>	<b>244</b>	<b>289</b>
<b>Max Speed (G10/G20)</b>	<b>8 000</b>	<b>6 500</b>	<b>5 600</b>	<b>5 000</b>	<b>4 400</b>	<b>3 900</b>	<b>3 600</b>	<b>3 200</b>	<b>2 900</b>	<b>2 650</b>	<b>2 450</b>	<b>2 150</b>
<b>Torque (N-m)</b>	<b>1 140</b>	<b>2 350</b>	<b>4 270</b>	<b>7 470</b>	<b>12 100</b>	<b>18 500</b>	<b>30 600</b>	<b>42 000</b>	<b>56 600</b>	<b>74 000</b>	<b>90 400</b>	<b>135 000</b>
<b>kW / rpm</b>	<b>0,119</b>	<b>0,246</b>	<b>0,447</b>	<b>0,783</b>	<b>1,27</b>	<b>1,94</b>	<b>3,21</b>	<b>4,40</b>	<b>5,93</b>	<b>7,75</b>	<b>9,47</b>	<b>14,2</b>
<b>RPM</b>	<b>kW Ratings</b>											
<b>68</b>	8.09	16.7	30.4	53.2	86.4	132	218	299	403	527	644	966
<b>56</b>	6.66	13.8	25.0	43.8	71.1	109	180	246	332	434	530	795
<b>45</b>	5.36	11.1	20.1	35.2	57.2	87.3	144	198	267	349	426	639
<b>37</b>	4.40	9.10	16.5	29.0	47.0	71.8	119	163	219	287	350	525
<b>30</b>	3.57	7.38	13.4	23.5	38.1	58.2	96.3	132	178	233	284	426
<b>25</b>	2.98	6.15	11.2	19.6	31.8	48.5	80.3	110	148	194	237	355
<b>20</b>	2.38	4.92	8.94	15.7	25.4	38.8	64.2	88.0	119	155	189	284
<b>16.5</b>	1.96	4.06	7.38	12.9	21.0	32.0	53.0	72.6	97.8	128	156	234
<b>13.5</b>	1.61	3.32	6.03	10.6	17.1	26.2	43.3	59.4	80.1	105	128	192
<b>11</b>	1.31	2.71	4.92	8.61	14.0	21.3	35.3	48.4	65.2	85.3	104	156
<b>9</b>	1.07	2.21	4.02	7.05	11.4	17.5	28.9	39.6	53.4	69.8	85.2	128
<b>7.5</b>	0.893	1.85	3.35	5.87	9.53	14.6	24.1	33.0	44.5	58.1	71.0	107
<b>5</b>	0.595	1.23	2.24	3.92	6.35	9.70	16.1	22.0	29.7	38.8	47.4	71.0

# Service Factors

**TABLE 4 — Gear Coupling Service Factors for Motor ♦ and Turbine Drives**

Service factors listed are typical values based on normal operation of the drive systems.

## Alphabetical listing of applications

<b>AERATOR</b> .....2,0
<b>AGITATORS</b>
Vertical and Horizontal
Screw, Propeller, Paddle.....1,0
<b>BARGE HAUL PULLER</b> .....1,5
<b>BLOWERS</b>
Centrifugal.....1,0
Lobe or Vane.....1,25
<b>CAR DUMPERS</b> .....2,5
<b>CAR PULLERS</b> .....1,5
<b>CLARIFIER OR CLASSIFIER</b> .....1,0
<b>COMPRESSORS</b>
Centrifugal.....1,0
Rotary, Lobe or Vane.....1,25
Rotary, Screw.....1,0
Reciprocating
Direct Connected..... Refer to Factory
Without Flywheel..... Refer to Factory
*With Flywheel and Gear
between Compressor
and Prime Mover
1 cylinder, single acting.....3,0
1 cylinder, double acting.....3,0
2 cylinders, single acting.....3,0
2 cylinders, double acting.....3,0
3 cylinders, single acting.....3,0
3 cylinders, double acting.....2,0
4 or more cyl., single act.....1,75
4 or more cyl., double act.....1,75
▲ <b>CONVEYORS</b>
Apron, Assembly, Belt, Chain,
Flight, Screw.....1,0
Bucket.....1,25
Live Roll, Shaker and
Reciprocating.....3,0
♣ <b>CRANES AND HOIST</b>
Main Hoist.....1,75▲
Skip Hoist.....1,75▲
Slope.....1,5
Bridge, Travel or Trolley.....1,75
<b>DYNAMOMETER</b> .....1,0
<b>ELEVATORS</b>
Bucket, Centrifugal Discharge.....1,25
Freight or Passenger Not Approved
Gravity Discharge.....1,25
<b>ESCALATORS Not Approved</b>
<b>EXCITER, GENERATOR</b> .....1,0
<b>EXTRUDER, PLASTIC</b> .....1,5
<b>FANS</b>
Centrifugal.....1,0
Cooling Tower.....2,0
Forced Draft — Across the
Line start.....1,5
Forced Draft Motor
Driven thru fluid or
electric slip clutch.....1,0
Gas Recirculating.....1,5
Induced Draft with damper
control or blade cleaner.....1,25
Induced Draft without controls.....2,0
<b>FEEDERS</b>
Apron, Belt, Disc, Screw.....1,0
Reciprocating.....2,5
<b>GENERATORS</b>
Even Load.....1,0
Hoist or Railway Service.....1,5
Welder Load.....2,0
<b>HAMMERMILL</b> .....1,75

♦ Add .25 to the required service factor for Type GL slide coupling applications where axial movement occurs more than 5 times per hour. When electric motors, generators, engines, compressors and other machines are fitted with sleeve or straight roller bearings, use limited axial end float couplings to protect the bearings. Order limited end float discs with the coupling.

\* For balanced opposed design, refer to the Factory.

▲ If people are occasionally transported, refer to the Factory for the selection of the proper size coupling.

♣ For high peak load applications (such as Metal Rolling Mills) refer to the Factory.

**TABLE 5 ▼ — Engine Drive Service Factors**

Service Factors for engine drives are those required for applications where good flywheel regulation prevents torque fluctuations greater than ±20%. For drives where torque fluctuations are greater or where the operation is near a serious critical or torsional vibration, a mass elastic study is necessary.

No. of Cylinders	4 or 5 ▼						6 or more ▼					
	1,0	1,25	1,5	1,75	2,0	2,5	1,0	1,25	1,5	1,75	2,0	2,5
<b>Table 1 S.F.</b>	1,0	1,25	1,5	1,75	2,0	2,5	1,0	1,25	1,5	1,75	2,0	2,5
<b>Engine S.F.</b>	2,0	2,25	2,5	2,75	3,0	3,5	1,5	1,75	2,0	2,25	2,5	3,0

▼ To use Table 5, first determine application service factor from Table 4. Use that factor to determine ENGINE Service Factor from Table 5. When service factor from Table 4 is greater than 2.5, refer complete application details to the Factory for engineering review.







## Alphabetical listing of industries

<b>AGGREGATE PROCESSING, CEMENT, MINING KILNS; TUBE, ROD AND BALL MILLS</b>	<b>Service Factor</b>
Direct or on L.S. shaft of	
Reducer, with final drive	
Machined Spur Gears.....2,0	
Single Helical or	
Herringbone Gears.....1,75	
Conveyors, Feeders, Screens,	
Elevators..... See General Listing	
Crushers, Ore or Stone.....2,5	
Dryer, Rotary.....1,75	
Grizzly.....2,0	
Hammermill or Hog.....1,75	
Tumbling Mill or Barrel.....1,75	
<b>BREWING AND DISTILLING</b>	
Bottle and Can	
Filling Machines.....1,0	
Brew Kettle.....1,0	
Cookers, Continuous Duty.....1,25	
Lauter Tub.....1,5	
Mash Tub.....1,25	
Scale Hopper, Frequent Peaks.....1,75	
<b>CLAY WORKING INDUSTRY</b>	
Brick Press, Briquette Machine,	
Clay Working Machine,	
Pug Mill.....1,75	
<b>DREDGES</b>	
Cable Reel.....1,75	
Conveyors.....1,25	
Cutter head, Jig Drive.....2,0	
Maneuvering Winch.....1,5	
Pumps (uniform load).....1,5	
Screen Drive, Stacker.....1,75	
Utility Winch.....1,5	
<b>FOOD INDUSTRY</b>	
Beef Slicer.....1,75	
Bottling, Can Filling Machine.....1,0	
Cereal Cooker.....1,25	
Dough Mixer, Meat Grinder.....1,75	
<b>LUMBER</b>	
Band Resaw.....1,5	
Circular Resaw, Cut-off.....1,75	
Edger, Head Rig, Hog.....2,0	
Gang Saw	
(Reciprocating)..... Refer to Factory	
Log Haul.....2,0	
Planer.....1,75	
Rolls, Non-Reversing.....1,25	
Rolls, Reversing.....2,0	
Sawdust Conveyor.....1,25	
Slab Conveyor.....1,75	
Sorting Table.....1,5	
Trimmer.....1,75	
♣ <b>METAL ROLLING MILLS</b>	
Coilers (Up or Down) Cold	
Mills only.....1,5	
Coilers (Up or Down) Hot	
Mills only.....2,0	
Coke Plants	
Pusher Ram Drive.....2,5	
Door Opener.....2,0	
Pusher or Larry Car	
Traction Drive.....3,0	
Continuous Caster.....1,75	
Cold Mills —	
Strip Mills..... Refer to Factory	
Temper Mills..... Refer to Factory	
Cooling Beds.....1,5	
Drawbench.....2,0	
Feed Rolls - Blooming Mills.....3,0	
Furnace Pushers.....2,0	
Hot and Cold Saws.....2,0	
Hot Mills —	
Strip or Sheet Mills..... Refer to Factory	
Reversing Blooming..... Refer to Factory	
or Slabbing Mills..... Refer to Factory	
Edger Drives..... Refer to Factory	
Ingot Cars.....2,0	
Manipulators.....3,0	
Merchant Mills..... Refer to Factory	
Mill Tables	
Roughing Breakdown	
Mills.....3,0	
Hot Bed or Transfer,	
non-reversing.....1,5	
Runout, reversing.....3,0	
Runout, non-reversing,	
non-plugging.....2,0	
Reel Drives.....1,75	
Rod Mills..... Refer to Factory	
Screwdown.....2,0	
Seamless Tube Mills	
Piercer.....3,0	
Thrust Block.....2,0	
Tube Conveyor Rolls.....2,0	
Reeler.....2,0	
Kick Out.....2,0	
Shear Croppers..... Refer to Factory	
Sidguards.....3,0	

<b>Service Factor</b>	<b>Service Factor</b>
Skelp Mills..... Refer to Factory	
Slitters, Steel Mill Only.....1,75	
Soaking Pit Cover Drives —	
Lift.....1,0	
Travel.....2,0	
Straighteners.....2,0	
Unscramblers (Billet Bundle	
Busters).....2,0	
Wire Drawing Machinery.....1,75	
<b>OIL INDUSTRY</b>	
Chiller.....1,25	
Oilwell Pumping (not over	
150% peak torque).....2,0	
Paraffin Filter Press.....1,5	
Rotary Kiln.....2,0	
<b>PAPER MILLS</b>	
Barker Auxiliary, Hydraulic.....2,0	
Barker, Mechanical.....2,0	
Barking Drum	
L.S. shaft of reducer with	
final drive - Helical	
or Herringbone Gear.....2,0	
Machined Spur Gear.....2,5	
Cast Tooth Spur Gear.....3,0	
Beater & Pulper.....1,75	
Bleachers, Coaters.....1,0	
Calender & Super Calender.....1,75	
Chipper.....2,5	
Converting Machine.....1,25	
Couch.....1,75	
Cutter, Felt Whipper.....2,0	
Cylinder.....1,75	
Dryer.....1,75	
Felt Stretcher.....1,25	
Fourdrinier.....1,75	
Jordan.....2,0	
Log Haul.....2,0	
Line Shaft.....1,5	
Press.....1,75	
Pulp Grinder.....1,75	
Reel, Rewinder, Winder.....1,5	
Stock Chest, Washer,	
Thickener.....1,5	
Stock Pumps, Centrifugal	
Constant Speed.....1,0	
Frequent Speed Changes	
Under Load.....1,25	
Suction Roll.....1,75	
Vacuum Pumps.....1,25	
<b>RUBBER INDUSTRY</b>	
Calender.....2,0	
Cracker, Plasticator.....2,5	
Extruder.....1,75	
Intensive or Banbury Mixer.....2,5	
Mixing Mill, Refiner or Sheeter	
One or two in line.....2,5	
Three or four in line.....2,0	
Five or more in line.....1,75	
Tire Building Machine.....2,5	
Tire & Tube Press Opener	
(Peak Torque).....1,0	
Tuber, Strainer, Pelletizer.....1,75	
Warming Mill	
One or two Mills in line.....2,0	
Three or more Mills in line.....1,75	
Washer.....2,5	
<b>SEWAGE DISPOSAL EQUIPMENT</b>	
Bar Screen, Chemical Feeders,	
Collectors, Dewatering	
Screen, Grit Collector.....1,0	
<b>SUGAR INDUSTRY</b>	
Cane Carrier & Leveler.....1,75	
Cane Knife & Crusher.....2,0	
Mill Stands, Turbine Driver	
With all helical or	
Herringbone gears.....1,5	
Electric Drive or Steam Engine	
Drive with Helical,	
Herringbone, or Spur Gears	
with any Prime Mover.....1,75	
<b>TEXTILE INDUSTRY</b>	
Batcher.....1,25	
Calender, Card Machine.....1,5	
Cloth Finishing Machine.....1,5	
Dry Can, Loom.....1,5	
Dyeing Machinery.....1,25	
Knitting Machine..... Refer to Falk	
Mangle, Napper, Soaper.....1,25	
Spinner, Tenter Frame, Winder.....1,5	

**SERVICE FACTORS:** are a guide, based on experience of the ratio between coupling catalog rating and system characteristics. The system characteristics are best measured with a torque meter.

**TABLE 6 — Service Factors**

Torque Demands Driven Machine	Typical applications for electric motor or turbine driven equipment	Typical Service Factor
	Constant Torque such as Centrifugal Pumps, Blowers, and Compressors.	1.0
	Continuous duty with some torque variations including Extruders, Forced Draft Fans.	1.5
	Light shock loads from Briquetting Machine, Rubber Calender, or Crane and Hoist.	2.0
	Moderate shock loading as expected from a Car Dumper, Ball Mill, or Vibrating Screen.	2.5
	Heavy shock load with some negative torques from Crushers, Hammer Mill, and Barking Drum.	3.0
	Applications like Reciprocating Compressors with frequent torque reversals, which do not necessarily cause reverse rotations.	Consult Rexnord Engineering

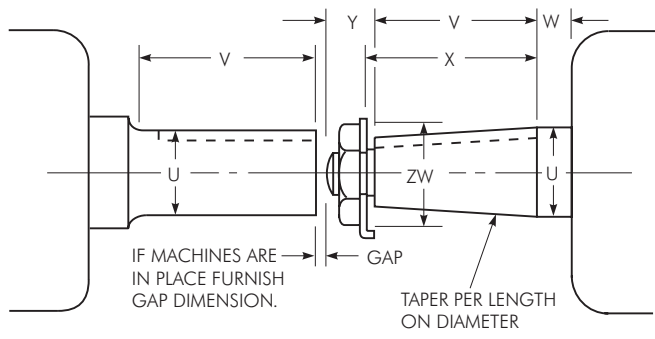

# How to Order

The following information is necessary to quote or ship to your exact requirements. Prompt service is assured if this information is given on your inquiry or order.

1. Application: Drive & Driven
2. Power: Normal kW, Maximum kW or Torque (Nm)
3. Speed (RPM)
4. Quantity
5. Coupling Size and Type, Horizontal, Vertical; e. g., Size 1010, Type G20
6. Shaft gap or distance between shaft ends (BE Dimension)
7. Bore Sizes will be furnished as per Table 35 on Page 55 unless specified differently.
8. Shaft Dimensions as follows:

### For Straight Shafts

<b>Driving Shaft</b>	Diameter U _____	<b>Driven Shaft</b>	Diameter U _____
	Length V _____		Length V _____
	Keyway _____		Keyway _____

**NOTE:** Provide shaft tolerances if different than those shown in Table 25, on Page 51. For other shaft/bore requirements, consult the Factory.

**For Taper Shafts:** Specify if keyway is to be parallel to the axis or to the bore.

Diameter U _____	Across Flats _____
Length V _____	Corners ZW _____
Length W _____	Taper per Foot _____
Length X _____	Keyway _____
Length Y _____	

## General Information

- Rexnord standards apply unless otherwise specified.
- Dimensions are for reference only and are subject to change without notice unless specified.
- Unless otherwise specified, coupling hubs will be bored for an INTERFERENCE FIT without a setscrew. Clearance fit hubs with a setscrew can be supplied if specified.

## Reference Notes

- † Peak torque capacity is two times the published rating.
- ‡ Consult Factory for higher speeds. Balancing may allow up to a 50% increase in speeds shown.
- Maximum bores are reduced for hubs furnished with an INTERFERENCE FIT and a setscrew over the keyway. Maximum bores may also be reduced when puller bolt holes are required. Refer to Tables 13 & 14 on Page 38. Bore capacities can be increased beyond values shown if the coupling torque rating is reduced. Refer to the Factory. Recommended key sizes for the listed maximum bores are shown in Table 11, Page 37, and Table 24, Page 51.
- Minimum bore is the smallest bore to which a RSB (rough stock bore) hub can be bored. Depending upon coupling size, rough stock bore hubs may have only a blind centering hole or a through hole that will permit remachining of the hubs to the minimum bores specified.

# Type GC02 Continuous Sleeve

## Double Engagement/Dimensions — Millimeters

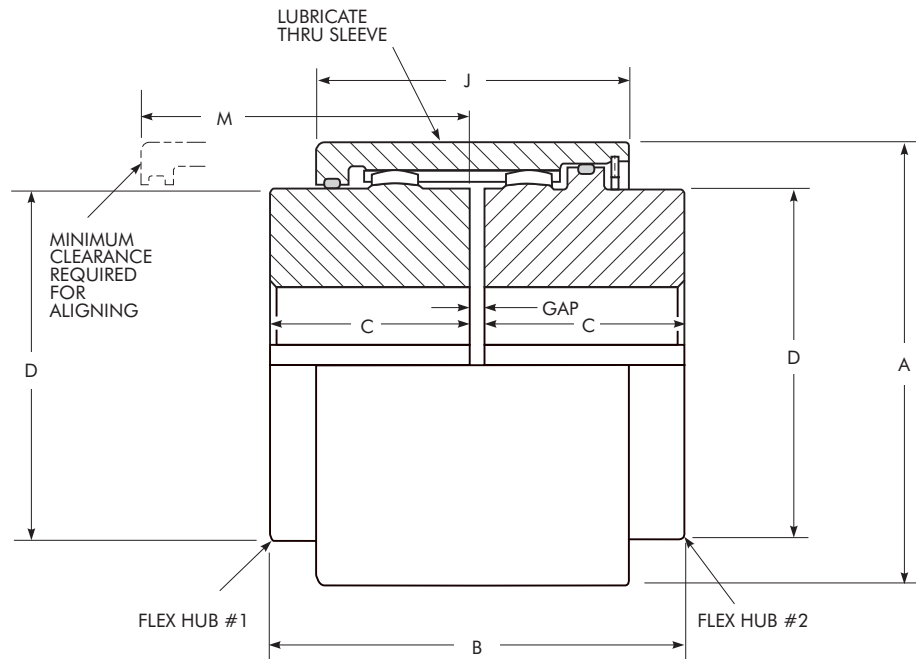

SIZE ★	Torque Rating (Nm) †	Allow Speed rpm ‡	Max Bore (mm) •	Min. Bore (mm) ▫	Cplg Wt With No Bore (kg)	Lube Wt (kg)	DIMENSIONS — Millimeters							SIZE ★
							A	B	C	D	J	M	Gap	
<b>1010GC</b>	1 140	5300	50	12,7	3,45	0,0113	88,9	88,8	42,9	68,6	61,2	65	3	<b>1010GC</b>
<b>1015GC</b>	2 350	4300	65	19,0	6,17	0,0283	109,2	101,6	49,3	86,4	76,2	81	3	<b>1015GC</b>
<b>1020GC</b>	4 270	3700	78	25,4	11,3	0,0425	132,1	127,0	62,0	105,2	94,5	99	3	<b>1020GC</b>
<b>1025GC</b>	7 470	3300	98	31,8	21,3	0,0652	163,6	159,0	77,0	130,6	109,1	116	5	<b>1025GC</b>
<b>1030GC</b>	12 100	2900	111	38,1	34,0	0,0936	190,5	187,4	91,2	152,4	119,9	126	5	<b>1030GC</b>
<b>1035GC</b>	18 500	2600	134	50,8	51,7	0,1219	215,9	218,8	106,4	177,8	133,5	140	6	<b>1035GC</b>

★ See Page 15 for General Information and Reference Notes.



# Type GC05 Continuous Sleeve

## Single Engagement/Dimensions — Millimeters

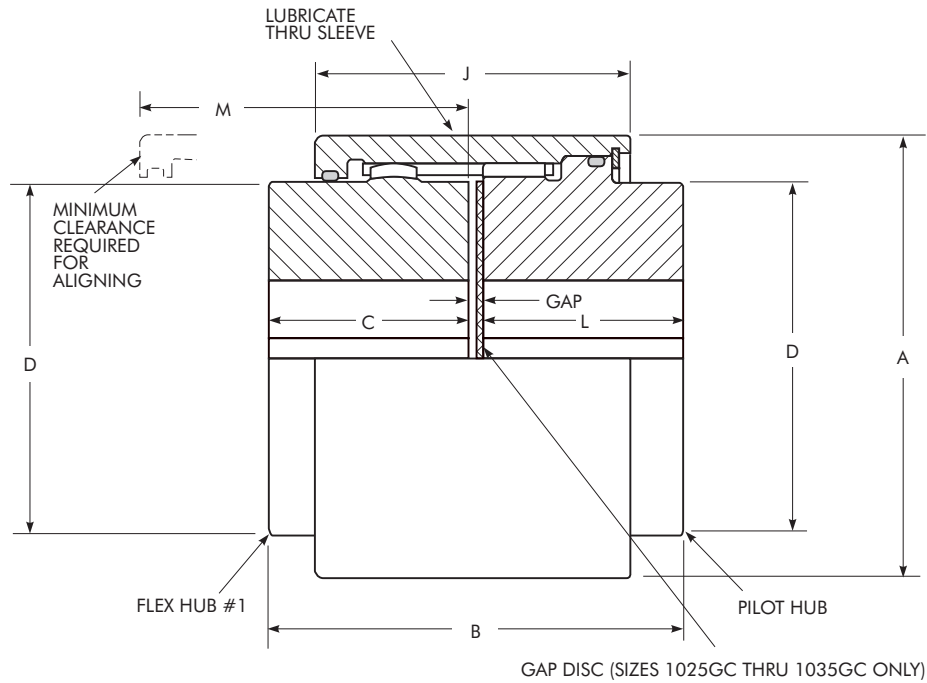

SIZE ★	Torque Rating (Nm) †	Allow Speed rpm ‡	Max Bore (mm) •	Min. Bore (mm) ▣	Cplg Wt With No Bore (kg)	Lube Wt (kg)	DIMENSIONS — Millimeters							SIZE ★	
							A	B	C	D	J	L	M		Gap
1010GC	1 140	5300	50	12,7	3,49	0,00850	88,9	88,9	42,9	68,6	61,2	42,9	65	3	1010GC
1015GC	2 350	4300	65	19,0	6,40	0,0198	109,2	103,6	49,3	86,4	76,2	51,1	81	3	1015GC
1020GC	4 270	3700	78	25,4	11,7	0,0312	132,1	128,8	62,0	105,2	94,5	63,8	99	3	1020GC
1025GC	7 470	3300	98	31,8	21,8	0,0522	163,6	158,8	77,0	130,6	109,1	77,0	116	5	1025GC
1030GC	12 100	2900	111	38,1	34,6	0,0730	190,5	187,2	91,2	152,4	119,9	91,2	126	5	1030GC
1035GC	18 500	2600	134	50,8	52,2	0,0957	215,9	219,2	106,4	177,8	133,5	106,4	140	6	1035GC

★ See Page 15 for General Information and Reference Notes.

# Type GC05 Continuous Sleeve

## Floating Shaft Single Engagement/Dimensions — Millimeters

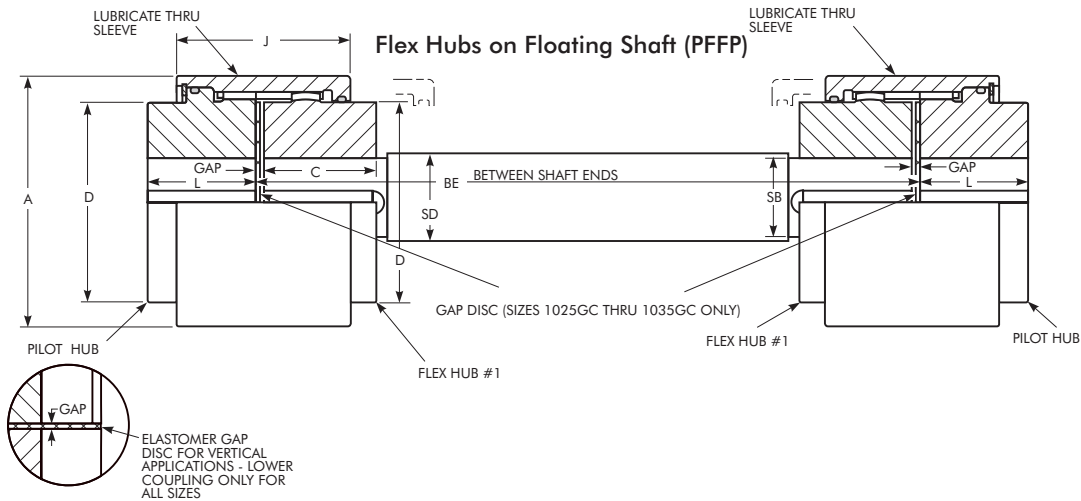

MINIMUM CLEARANCE REQUIRED FOR ALIGNING

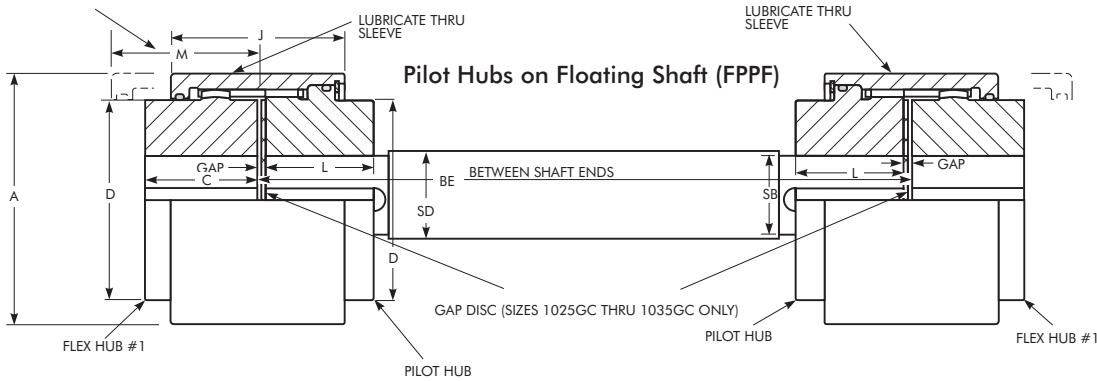

SIZE *	Assembly Torque Rating Nm †	Max Bore (mm) *	Min Bore (mm) †	Wt - Each Cplg w/o Bore (kg)	Lube Wt (kg)	DIMENSIONS — Millimeters								SIZE *	
						A	BE Min		C	D	J	L	M		Gap
							PF-FP	FP-PF							
1010GC	1 140	50	12,7	3,49	0,00850	88,9	190	92,2	42,9	68,6	61,2	42,9	65	3	1010GC
1015GC	2 350	65	19,0	6,40	0,0198	109,2	235	104,9	49,3	86,4	76,2	51,1	81	3	1015GC
1020GC	4 270	78	25,4	11,7	0,0312	132,1	290	130,3	62,0	105,2	94,5	63,8	99	3	1020GC
1025GC	7 470	98	31,8	21,8	0,0522	163,6	338	163,6	77,0	130,6	109,1	77,0	116	5	1025GC
1030GC	12 100	111	38,1	34,6	0,0730	190,5	368	192,0	91,2	152,4	119,9	91,2	126	5	1030GC
1035GC	18 500	134	50,8	52,2	0,0957	215,9	413	225,6	106,4	177,8	133,5	106,4	140	6	1035GC

SIZE *	Assembly Torque Rating ▲ Nm †	SB Shaft End Diameter (mm)	SD Shaft Diameter (mm)	Weight (kg per mm)	WR <sup>2</sup> (KgM <sup>2</sup> per mm)	Maximum BE (mm) for Various RPM's*							SIZE *
						1750	1430	1170	870	720	580	540 or Less	
						1010G	439 1 140	38,1 47,6	39,7 50,8	0,00964 0,0159	0,00000196 0,00000518	1 371 1 549	
1015G	1 169 2 350	50,8 60,3	54,0 63,5	0,0179 0,0248	0,00000657 0,0000126	1 600 1 752	1 778 1 930	1 955 2 133	2 286 2 463	2 514 2 717	2 794 3 022	2 870 3 124	1015G
1020G	2 282 4 270	63,5 73,0	66,7 76,2	0,0273 0,0357	0,0000152 0,0000259	1 778 1 905	1 981 2 108	2 184 2 336	2 540 2 717	2 794 2 971	3 098 3 237	3 200 3 429	1020G
1025G	4 463 7 470	79,4 92,1	82,6 95,2	0,0420 0,0559	0,0000357 0,0000634	1 981 2 133	2 209 2 362	2 438 2 616	2 819 3 022	3 098 3 327	3 454 3 708	3 556 3 835	1020G
1030G	8 508 12 100	98,4 104,8	101,6 108,0	0,0636 0,0718	0,0000820 0,000104	2 209 2 260	2 438 2 514	2 692 2 794	3 124 3 225	3 454 3 556	3 835 3 962	3 962 4 064	1030G
1035G	13 333 18 500	114,3 123,8	120,6 127,0	0,0896 0,0993	0,000163 0,000200	2 413 2 463	2 667 2 717	2 946 3 022	3 403 3 505	3 759 3 860	4 191 4 292	4 292 4 419	1035G

\* Refer to Page 15 for General Information and Reference Notes.

▲ Limited by coupling size, shaft end diameter or both. Refer to Page 22 for selection procedure.

♣ Interpolate for intermediate speeds. Maximum BE is based on 70% of critical speed. Refer to the Factory for higher running speeds.

# Type G20 Standard Flanged Sleeve

## Double Engagement/Dimensions — Millimeters

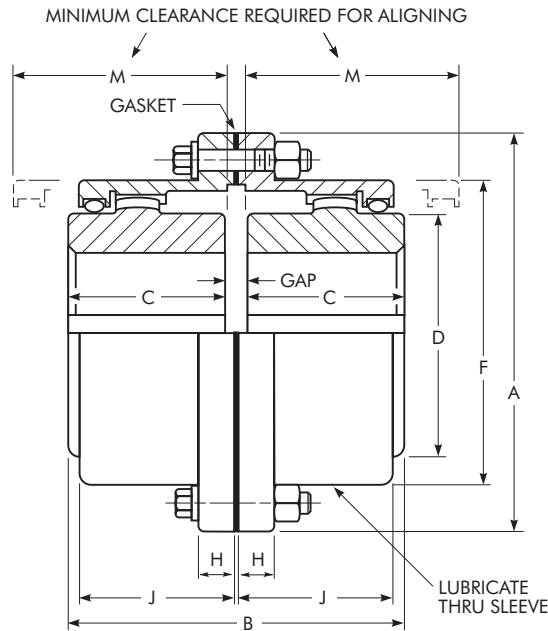

For Sizes 1010G thru 1055G, Type G10 Shrouded Bolts furnished only when specified on order.

SIZE *	Torque Rating (Nm) †	Allow Speed rpm ‡	Max Bore (mm) •	Min Bore (mm) ■	Cplg Wt With No Bore-kg		Lube Wt (kg)	DIMENSIONS — Millimeters								SIZE *	
					G10	G20		A	B	C	D	F	H	J	M		Gap
1010G	1 140	8000	50	13	4,08	4,54	0,0408	115,9	88,9	42,9	68,6	83,8	14,0	38,9	51	3	1010G
1015G	2 350	6500	65	20	7,71	9,07	0,0726	152,4	101,6	49,3	86,4	105,2	19,0	47,8	61	3	1015G
1020G	4 270	5600	78	26	13,6	15,9	0,113	177,8	127,0	62,0	105,2	126,5	19,0	59,4	77	3	1020G
1025G	7 470	5000	98	32	24,9	29,5	0,2127	212,7	158,9	77,0	130,6	154,9	21,8	71,6	92	5	1025G
1030G	12 100	4400	111	39	38,6	43,1	0,363	239,7	187,4	91,2	152,4	180,3	21,8	83,8	107	5	1030G
1035G	18 500	3900	134	51	61,2	68,0	0,544	279,4	218,9	106,4	177,8	211,3	28,4	97,5	130	6	1035G
1040G	30 600	3600	160	64	88,5	97,5	0,907	317,5	247,3	120,6	209,6	245,4	28,4	111,3	145	6	1040G
1045G	42 000	3200	183	77	127	136	1,04	346,1	277,7	134,9	235,0	274,1	28,4	122,9	166	8	1045G
1050G	56 600	2900	200	89	177	191	1,77	388,9	314,3	153,2	254,0	305,8	38,1	140,7	183	8	1050G
1055G	74 000	2650	220	102	238	249	2,22	425,4	344,3	168,1	279,4	334,3	38,1	158,0	204	8	1055G
1060G	90 400	2450	244	115	...	306	3,18	457,2	384,4	188,2	304,8	366,0	25,4	169,2	229	8	1060G
1070G	135 000	2150	289	127	...	485	4,35	527,0	451,5	220,7	355,6	424,9	28,4	195,6	267	10	1070G

★ See Page 15 for General Information and other Reference Notes.

**TABLE 7 — Limited End Float & Standard Gap Disc Dimensions**

SIZE	DIMENSIONS — Millimeters				
	B	End Float ♦	Gap Disc *		Gap
			Thickness	Dia	
1010G	90,9	2,39	4	75	5
1015G	103,6	2,39	4	94	5
1020G	129,8	2,39	5	114	6
1025G	162,3	2,39	7	141	8
1030G	191,5	2,39	8	165	9
1035G	223,3	4,78	8	192	10
1040G	251,7	4,78	8	227	10
1045G	283,2	4,78	11	253	13
1050G	319,8	4,78	11	278	13
1055G	350,5	4,78	12	305	14
1060G	392,4	4,78	14	333	16
1070G	459,7	4,78	16	384	18

♦ If these values exceed one-half rotor end float or equivalent manufacturer's specification, refer to the Factory.

\* Gap disc material: Neoprene, 70 durometer.

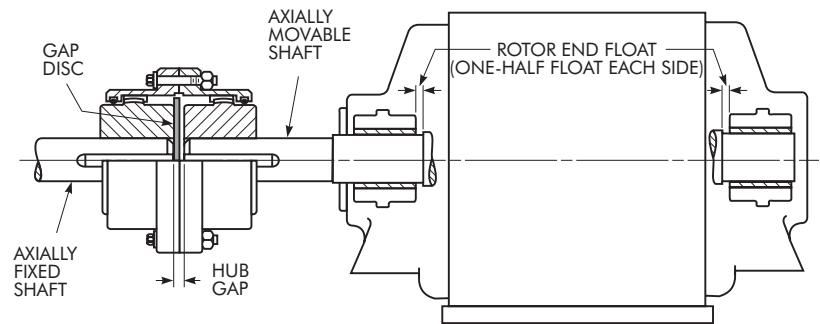

# Type G32 Standard Flanged Sleeve Spacer/Dimensions — Millimeters

Without Limited End Float

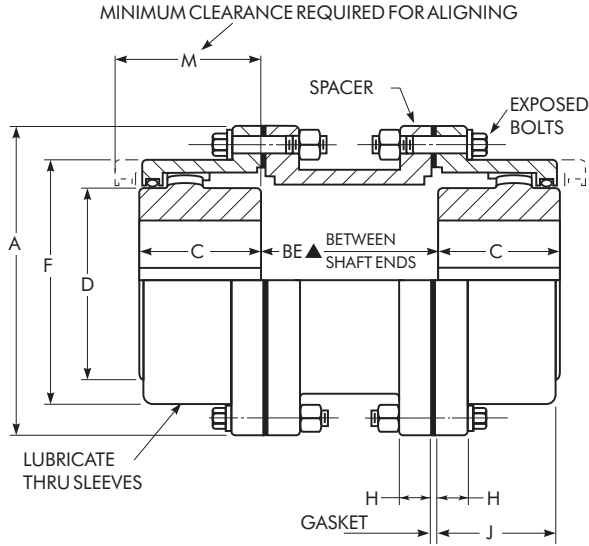

SIZE	DIMENSIONS — Millimeters		
	End Float †	SG	Addition to Stock BE Length *
1015G	2,4	0,5969	2,2
1020G	2,4	0,5969	2,7
1025G	2,4	0,5969	3,7
1030G	2,4	0,5969	4,7
1035G	4,8	1,19	4,7
1040G thru 1070G	4,8	1,19	None

† Refer to the Factory if these values exceed one-half the rotor end float or the equipment manufacturers' specifications.  
\* Couplings with stock spacers and limited end float must add applicable addition to the BE (Between Shaft Ends) dimension.

SIZE	BE Spacers in Stock — mm				
	89	111	114	127	178
1010G	•	•	•	•	•
1015G	•	•	•	•	•
1020G	•	•	•	•	•
1025G	•	•	•	•	•
1030G	•	•	•	•	•
1035G	•	•	•	•	•

◆ Bolt holes staggered for assembly clearance.

With Limited End Float  
(Refer to drawing at left for balance of dimensions.)

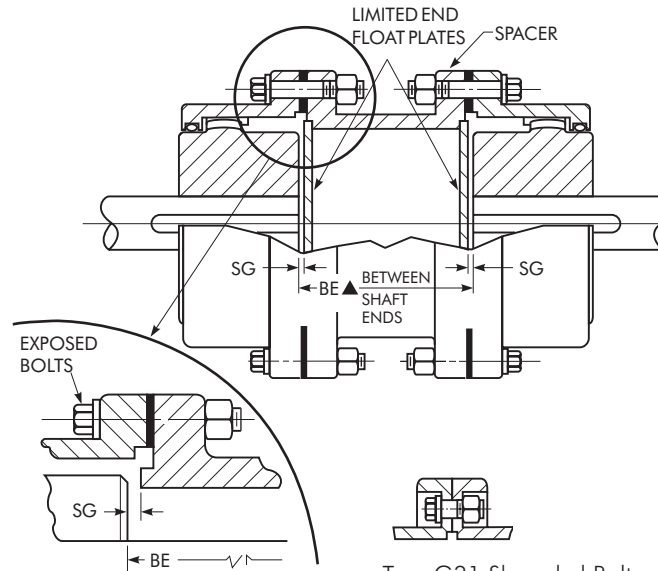

NON-STOCK SPACER DESIGN  
SIZES 1010 THRU 1070G32.

Type G31 Shrouded Bolts furnished only when specified on order.

SIZES *	Torque Rating (Nm) †	Allow Speed rpm ‡	Max Bore (mm) •	Min Bore (mm) ■	Coupling Wt-kg		Lube Wt-kg		DIMENSIONS — Millimeters										SIZE *
					Cplg Wt With No Bore and Min BE	Extra Spacer Wt per mm of Length	Min Wt Less Spacer	Plus per mm of Spacer Length	A	BE Min ▲		BE Max	C	D	F	H	J	M	
										G31	G32								
1010G	1 140	7000	50	13	6,80	0,0120	0,0408	...	115,9	82	82	311	42,9	68,6	83,8	14,0	38,9	48	1010G
1015G	2 350	5500	65	20	13,6	0,0127	0,0726	...	152,4	82	82	311	49,3	86,4	105,2	19,0	47,8	56	1015G
1020G	4 270	4600	78	26	20,4	0,0166	0,113	0,000536	177,8	82	82	311	62,0	105,2	126,5	19,0	59,4	69	1020G
1025G	7 470	4000	98	32	38,6	0,0205	0,227	0,00107	212,7	108	95	311	77,0	130,6	154,9	21,8	71,6	81	1025G
1030G	12 100	3600	111	39	54,4	0,0236	0,363	0,00107	239,7	108	95	311	91,2	152,4	180,3	21,8	83,8	94	1030G
1035G	18 500	3100	134	51	88,5	0,0359	0,544	0,00214	279,4	130	120	311	106,4	177,8	211,3	28,4	97,5	107	1035G
1040G	30 600	2800	160	64	122,5	0,0500	0,907	0,00357	317,5	130	120	311	120,6	209,6	245,4	28,4	111,3	122	1040G
1045G	42 000	2600	183	77	166	0,0736	1,04	0,00357	346,1	130	120	311	134,9	235,0	274,1	28,4	122,9	135	1045G
1050G	56 600	2400	200	89	238	0,0814	1,77	0,00357	388,9	184	146	311	153,2	254,0	305,8	38,1	140,7	152	1050G
1055G	74 000	2200	220	102	306	0,0895	2,22	0,00357	425,4	184	146	311	168,1	279,4	334,3	38,1	158,0	173	1055G
1060G	90 400	2100	244	115	358	0,117	3,18	0,00357	457,2	...	146	311	188,2	304,8	366,0	25,4	169,2	183	1060G
1070G	135 000	1800	289	127	562	0,141	4,35	0,00357	527,0	...	146	311	220,7	355,6	424,9	28,4	195,6	208	1070G

★ See Page 15 for General Information and other Reference Notes.  
▲ BE is the distance between shaft ends whether standard (stock) or special spacer lengths are used.

# Type G52 Standard Flanged Sleeve

## Single Engagement/Dimensions — Millimeters

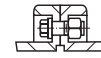
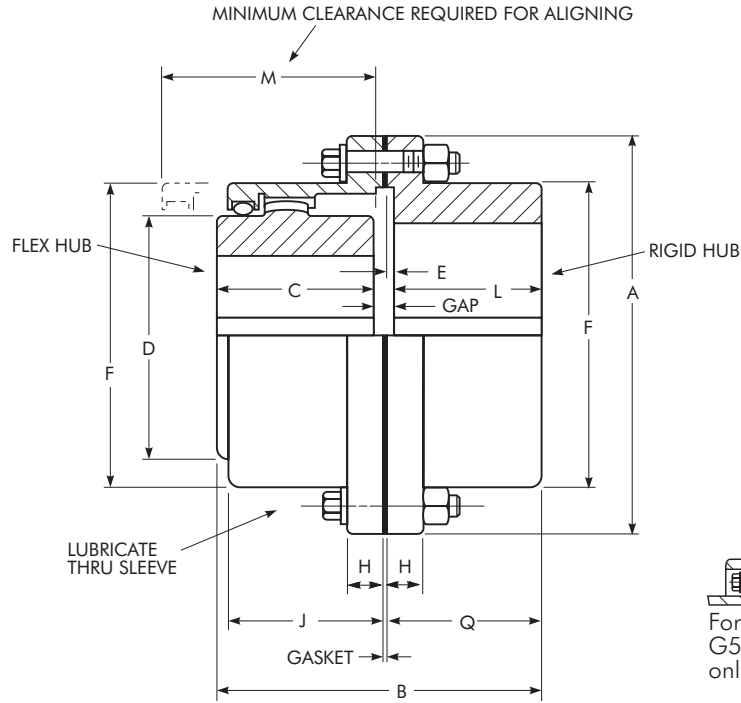

For Sizes 1010G thru 1055G, Type G51 Shrouded Bolts furnished only when specified on order.

SIZE ★	Torque Rating (Nm) †	Allow Speed rpm ‡	Max Bore (mm) •		Min Bore (mm) ■	Cplg Wt With No Bore—kg		Lube Wt (kg)	DIMENSIONS — Millimeters											SIZE ★	
			Flex Hub	Rigid Hub		G51	G52		A	B	C	D	E	F	H	J	L	M	Q		Gap
1010G	1 140	8000	50	65	13	4,08	4,54	0,0227	115,9	86,6	42,9	68,6	2,5	83,8	14,0	38,9	39,6	51	42,2	4	1010G
1015G	2 350	6500	65	80	20	8,16	9,07	0,0408	152,4	99,6	49,3	86,4	2,5	105,2	19,0	47,8	46,2	61	48,8	4	1015G
1020G	4 270	5600	78	98	26	13,6	15,9	0,0680	177,8	124,5	62,0	105,2	2,5	126,5	19,0	59,4	58,4	76	61,0	4	1020G
1025G	7 470	5000	98	118	32	24,9	27,2	0,118	212,7	155,4	77,0	130,6	2,5	154,9	21,8	71,6	73,7	91	76,2	5	1025G
1030G	12 100	4400	111	140	39	38,6	43,1	0,181	239,7	183,9	91,2	152,4	2,5	180,3	21,8	83,8	87,9	107	90,4	5	1030G
1035G	18 500	3900	134	163	51	61,2	68,0	0,272	279,4	214,1	106,4	177,8	2,5	211,3	28,4	97,5	102,1	130	104,6	6	1035G
1040G	30 600	3600	160	196	64	90,7	99,8	0,467	317,5	242,8	120,6	209,6	4,1	245,4	28,4	111,3	115,3	145	119,4	7	1040G
1045G	42 000	3200	183	216	77	129,3	136	0,557	346,1	273,1	134,9	235,0	4,1	274,1	28,4	122,9	130,6	165	134,6	8	1045G
1050G	56 600	2900	200	235	89	181,4	195	0,907	388,9	309,1	153,2	254,0	5,1	305,8	38,1	140,7	147,3	183	152,4	9	1050G
1055G	74 000	2650	220	266	102	251,7	263	1,13	425,4	349,5	168,1	279,4	5,1	334,3	38,1	158,0	172,7	203	177,8	9	1055G
1060G	90 400	2450	244	290	115	...	324	1,70	457,2	385,1	188,2	304,8	6,6	366,0	25,4	169,2	186,4	229	193,0	10	1060G
1070G	135 000	2150	289	340	127	...	508	2,27	527,0	453,6	220,7	355,6	8,4	424,9	28,4	195,6	220,2	267	228,6	13	1070G

★ See Page 15 for General Information and other Reference Notes.

# Type G52 Standard Flanged Sleeve Floating Shafts/Dimensions — Millimeters

A standard floating shaft assembly consists of two standard single engagement couplings, two gap discs and a connecting shaft.

A floating shaft can eliminate the need for additional bearing supports along the shaft because the shaft is supported at the ends by connected equipment through the single engagement couplings.

## Flex Hubs on Floating Shaft (RFFR)

Assembly of the flex hubs on the floating shaft allows for easier replacement in case of wear and allows the rigid hubs with their increased bore capacity to be used on the connected equipment shafts. This frequently means a smaller coupling size can be utilized.

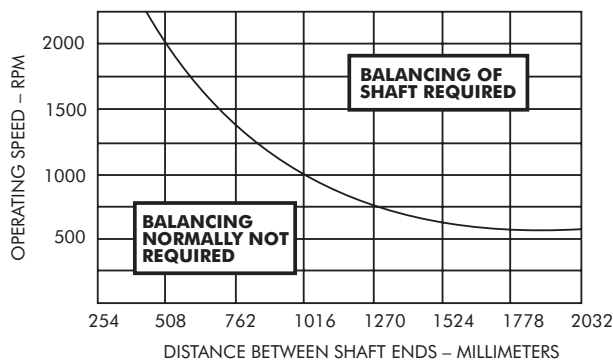

## Rigid Hubs on Floating Shaft (FRRF)

When the rigid hubs are on the floating shaft, shorter shaft spans can be accommodated, since no cover drawback is required. Since the flex hubs are outboard, the points of articulation are further apart, providing greater offset misalignment capacity.

## Solid Floating Shaft Selection

Single Engagement Type G52/GV52 couplings are used with floating shafts in either horizontal or vertical applications. For vertical applications select a Type GV coupling for the lower coupling assembly. Select floating shafts as follows:

1. Use the Standard or Formula Selection Methods, Pages 10-11 to select the couplings. Record the System Torque from standard selection method or Selection Torque from formula selection method.
2. From table below select a shaft diameter that has an assembly torque rating equal to or greater than the system or selection torque determined in coupling selection.
3. Check maximum "BE" for the shaft diameter selected and running speed for shaft length required from table below. Refer to graph at left to determine if shaft requires balancing.
4. If the application shaft length exceeds the maximum "BE" listed, select the next larger shaft diameter or the next larger size coupling. Consult the Factory for higher speeds or longer shaft lengths than listed below.

**NOTE:** For conditions that require a larger size coupling, consider a Tubular Shaft Design, refer complete application details to your local Rexnord Representative.

SIZE ★	Assembly Torque Rating ▲ Nm †	Floating Shafts — Millimeters										
		SB Shaft End Diameter (mm)	SD Shaft Diameter (mm)	Wt.-kg per mm	WR <sup>2</sup> kgm <sup>2</sup> per mm	Maximum BE (mm) for Various RPM's *						
						1750	1430	1170	870	720	580	540 or less
1010G	493	38,1	39,7	0,00964	0,00000196	1 371	1 524	1 676	1 955	2 159	2 387	2 463
	1 140	47,6	50,8	0,0159	0,00000518	1 549	1 727	1 905	2 209	2 438	2 717	2 794
1015G	1 169	50,8	54,0	0,0179	0,00000657	1 600	1 778	1 955	2 286	2 514	2 794	2 870
	2 349	60,3	76,2	0,0248	0,0000126	1 752	1 930	2 133	2 463	2 717	3 022	3 124
1020G	2 282	63,5	66,7	0,0273	0,0000152	1 778	1 981	2 184	2 540	2 794	3 098	3 200
	4 271	73,0	95,2	0,0557	0,0000259	1 905	2 108	2 336	2 717	2 971	3 327	3 429
1025G	4 463	79,4	82,6	0,0420	0,0000357	1 981	2 209	2 438	2 819	3 098	3 454	3 556
	7 474	92,1	95,2	0,0559	0,0000634	2 133	2 362	2 616	3 022	3 237	3 708	3 835
1030G	8 508	98,4	101,6	0,0636	0,0000820	2 209	2 438	2 692	3 124	3 454	3 835	3 962
	12 101	104,8	127,0	0,0718	0,000104	2 260	2 514	2 794	3 225	3 556	3 962	4 064
1035G	13 333	114,3	120,6	0,0896	0,000163	2 413	2 667	2 946	3 403	3 759	4 191	4 292
	18 508	123,8	146,0	0,0993	0,000200	2 463	2 717	3 022	3 505	3 860	4 292	4 419
1040G	24 327	139,7	146,0	0,131	0,000350	2 641	2 921	3 251	3 759	4 140	4 597	4 749
	30 609	146,0	165,1	0,143	0,000415	2 692	2 997	3 302	3 835	4 216	4 699	4 851
1045G	31 581	152,4	165,1	0,168	0,000572	2 819	3 124	3 454	3 987	4 394	4 902	5 029
	41 999	171,5	203,2	0,254	0,00131	3 124	3 454	3 810	4 445	4 876	5 435	5 588
1050G	37 886	161,9	165,1	0,168	0,000572	2 819	3 124	3 454	3 987	4 394	4 902	5 029
	56 597	187,3	203,2	0,254	0,00131	3 124	3 454	3 810	4 445	4 876	5 435	5 588
1055G	37 886	161,9	165,1	0,168	0,000572	2 819	3 124	3 454	3 987	4 394	4 902	5 029
	74 031	200,0	203,2	0,254	0,00131	3 124	3 454	3 810	4 445	4 876	5 435	5 588
1060G	71 410	200,0	203,2	0,254	0,00131	3 124	3 454	3 810	4 445	4 876	5 435	5 588
	90 404	215,9	217,4	0,291	0,00172	3 225	3 581	3 962	4 597	5 054	5 613	5 791
1070G	71 410	200,0	203,2	0,254	0,00131	3 124	3 454	3 810	4 445	4 876	5 435	5 588
	135 250	241,3	242,8	0,363	0,00268	3 403	3 784	4 191	4 851	5 334	5 943	6 121

★ Refer to Page 15 for General Information and Reference Notes.

▲ Assembly torque rating is limited by coupling size, shaft end diameter or both.

\* Interpolate for intermediate speeds. Maximum BE is based on 70% of critical speed. Refer to the Factory for higher running speeds.

# Type G52 Standard Flanged Sleeve

## Floating Shaft/Dimensions — Millimeters

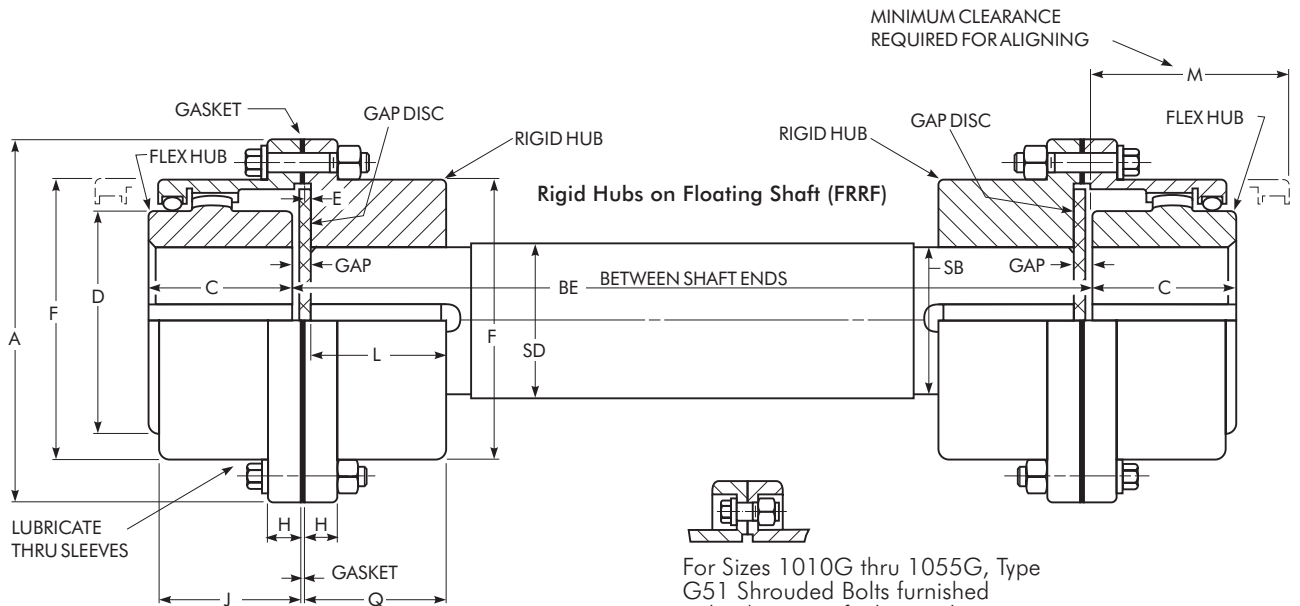
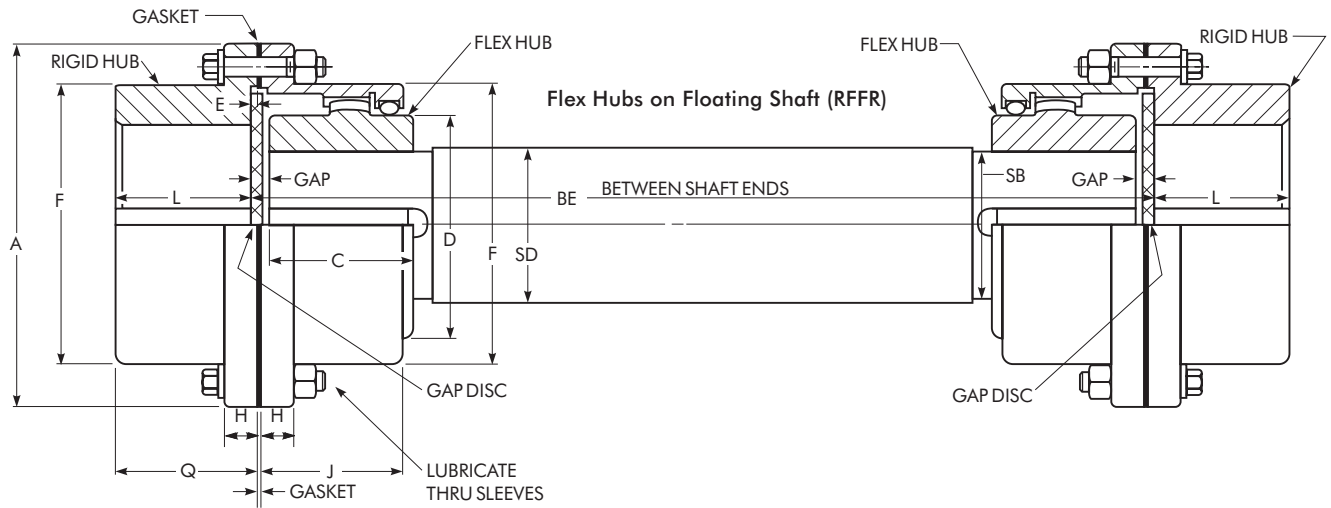

For Sizes 1010G thru 1055G, Type G51 Shrouded Bolts furnished only when specified on order.

SIZE ★	Max Bore (mm) •		Min Bore (mm) ■	Wt—One Cplg No Bore—kg		Lube Wt Per Cplg (kg)	DIMENSIONS — Millimeters												
	Flex Hub	Rigid Hub		G51	G52		A	BE Min		C	D	E	F	H	J	L	M	Q	Gap
								RFFR	FRRF										
1010G	50	65	13	4,08	4,54	0,0227	115,9	133	92	42,9	68,6	2,5	83,8	14,0	38,9	39,6	48	42,2	4
1015G	65	80	20	8,16	9,07	0,0408	152,4	159	105	49,3	86,4	2,5	105,2	19,0	47,8	46,2	56	48,8	4
1020G	78	98	26	13,6	15,9	0,0680	177,8	197	129	62,0	105,2	2,5	126,5	19,0	59,4	58,4	69	61,0	4
1025G	98	118	32	24,9	27,2	0,118	212,7	241	162	77,0	130,6	2,5	154,9	21,8	71,6	73,7	81	76,2	5
1030G	111	140	39	38,6	43,1	0,181	239,7	279	189	91,2	152,4	2,5	108,3	21,8	83,8	87,9	94	90,4	5
1035G	134	163	51	61,2	68,0	0,272	279,4	324	219	106,4	177,8	2,5	211,3	28,4	97,5	102,1	107	104,6	6
1040G	160	196	64	90,7	99,8	0,467	317,5	419	248	120,6	209,6	4,1	245,4	28,4	111,3	115,3	122	119,4	7
1045G	183	216	77	129,3	136	0,557	346,1	508	281	134,9	235,0	4,1	274,1	28,4	122,9	130,8	135	134,6	8
1050G	200	235	89	181,4	195	0,907	388,9	533	316	153,2	254,0	5,1	305,8	38,1	140,7	147,3	152	152,4	9
1055G	220	266	102	251,7	263	1,13	425,4	572	367	168,1	279,4	5,1	334,3	38,1	158,0	172,7	173	177,8	9
1060G	244	290	115	...	324	1,70	457,2	597	397	188,2	304,8	6,6	366,0	25,4	169,2	186,4	183	193,0	10
1070G	289	340	127	...	508	2,27	527,0	673	470	220,7	355,6	8,4	424,9	28,4	195,6	220,2	208	228,6	13

★ Refer to Page 15 for General Information and Reference Notes.

# Type GV20 Standard Flanged Sleeve

## Vertical Double Engagement/Dimensions — Millimeters

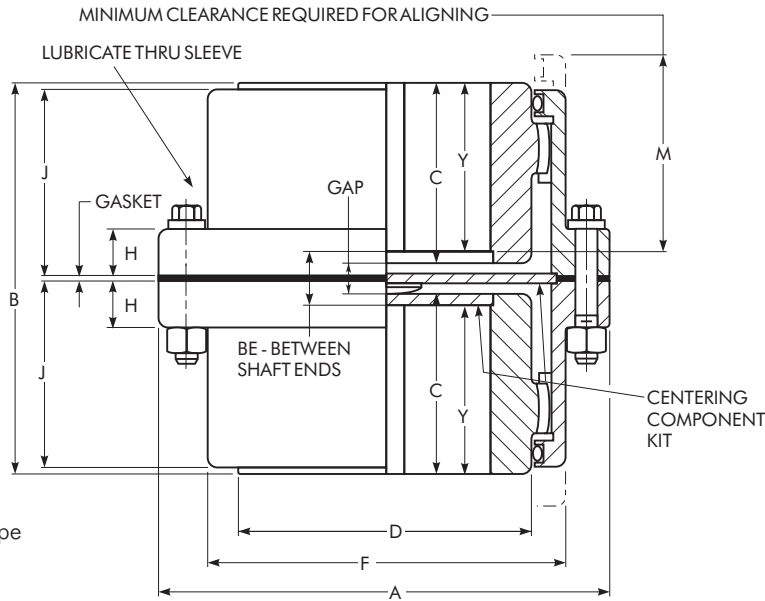

For Sizes 1010GV thru 1055GV, Type GV10 Shrouded Bolts furnished only when specified on order.

SIZE ★	Torque Rating (Nm) <sup>†</sup>	Allow Speed rpm	Max Bore (mm) •	Min Bore (mm) ▫	Cplg Wt With No Bore-kg		Lube Wt (kg)	DIMENSIONS — Millimeters										SIZE ★	
					GV10	GV20		A	B	C	D	F	H	J	M	Y	BE		Gap
1010GV	1 140	8000	50	13	3,63	4,08	0,0816	115,9	88,9	38,9	68,6	83,8	14,0	38,9	46	32,5	23,9	11	1010GV
1015GV	2 350	6500	65	20	7,71	8,62	0,1361	152,4	101,1	45,0	86,4	105,2	19,0	47,8	56	38,6	23,9	11	1015GV
1020GV	4 270	5600	78	26	13,6	14,5	0,2268	177,8	126,5	57,7	105,2	126,5	19,0	59,4	71	51,3	23,9	11	1020GV
1025GV	7 470	5000	98	32	23,6	26,3	0,4082	212,9	157,5	71,6	130,6	154,9	21,8	71,6	86	65,3	26,9	14	1025GV
1030GV	12 100	4400	111	39	36,3	40,8	0,6350	239,8	186,4	86,1	152,4	180,3	21,8	83,8	102	79,8	26,9	14	1030GV
1035GV	18 500	3900	134	51	59,0	65,8	0,9979	279,4	218,2	100,3	177,8	211,3	28,4	97,5	125	94,0	30,2	18	1035GV
1040GV	30 600	3600	160	64	88,4	97,5	1,45	317,5	246,9	112,3	209,6	245,4	28,4	111,3	140	105,9	35,1	22	1040GV
1045GV	42 000	3200	183	77	123	132	2,00	346,0	276,9	125,7	235,0	274,1	28,4	122,9	158	116,3	44,2	25	1045GV
1050GV	56 600	2900	200	89	172	186	2,86	388,9	313,4	144,0	254,0	305,8	38,1	140,7	175	134,6	44,2	25	1050GV
1055GV	74 000	2650	220	102	231	243	3,62	425,4	343,4	159,0	279,4	334,3	38,1	158,0	196	149,6	44,2	25	1055GV
1060GV	90 400	2450	244	115	...	302	4,81	457,2	384,0	177,8	304,8	366,0	25,4	169,2	221	168,1	47,8	29	1060GV
1070GV	135 000	2150	289	127	...	476	7,08	527,0	450,6	207,8	355,6	424,9	28,4	195,6	254	194,8	61,0	35	1070GV

★ See Page 15 for General Information and other Reference Notes.



# Type GV52 Standard Flanged Sleeve

## Vertical Single Engagement/Dimensions — Millimeters

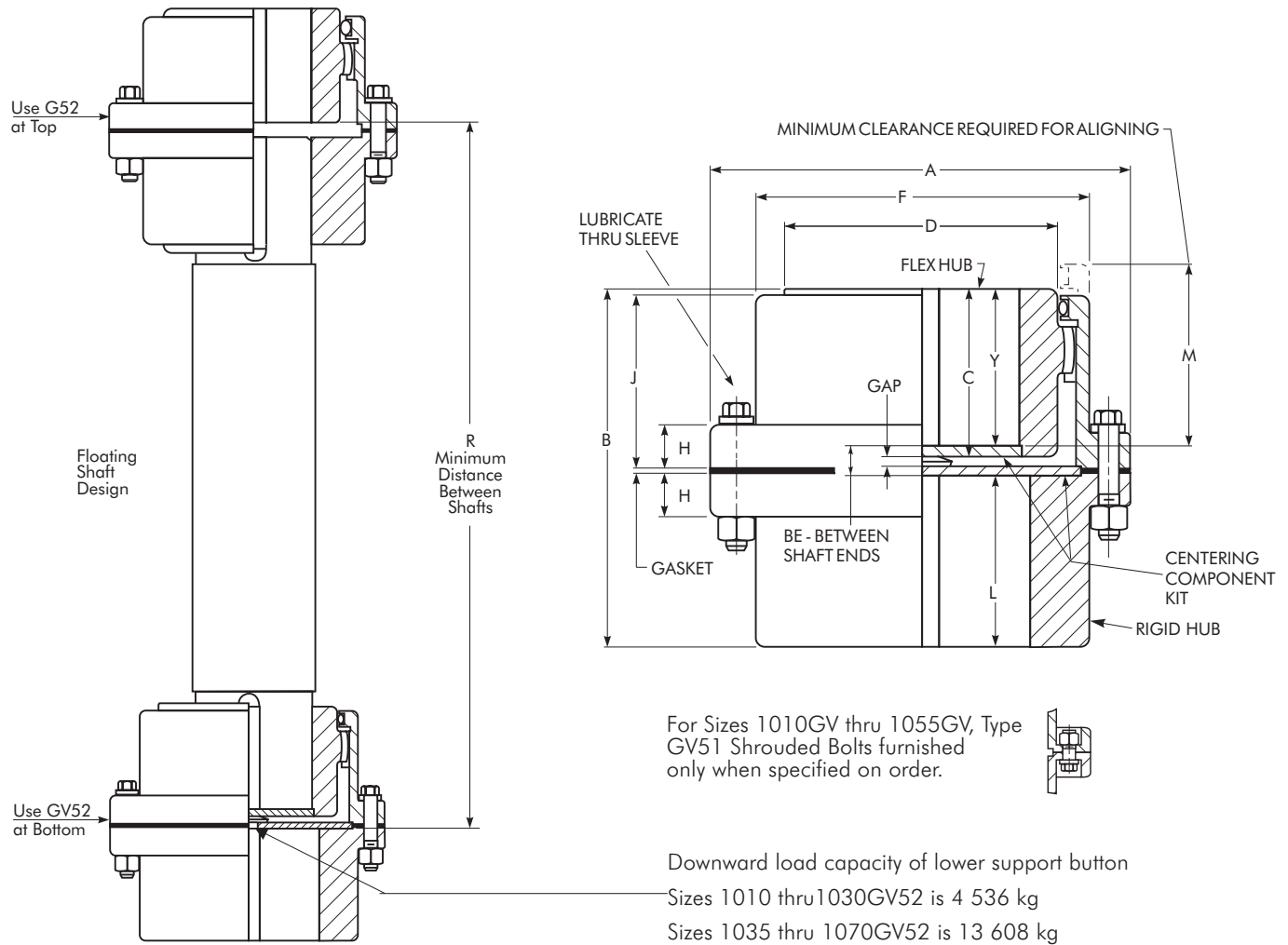

SIZE ★	Torque Rating (Nm) †	Allow Speed rpm ‡	Max Bore (mm) •		Min Bore (mm) ▯	Cplg Wt With No Bore-kg		Lube Wt (kg)	DIMENSIONS — Millimeters											SIZE ★		
			Flex Hub	Rigid Hub		GV51	GV52		A	B	C	D	F	H	J	L	M	R	Y		BE	Gap
1010GV	1 140	7000	50	65	13	4,08	4,54	0,0363	115,9	86,9	38,9	68,6	83,8	14,0	38,9	39,6	45,7	131,6	32,5	14,7	4	1010GV
1015GV	2 350	5500	65	80	20	8,16	9,07	0,0544	152,4	99,6	45,0	86,4	105,2	19,0	47,8	46,2	55,9	152,4	38,6	14,7	4	1015GV
1020GV	4 270	4600	78	98	26	14,5	15,9	0,0907	177,8	124,5	57,7	105,2	126,5	19,0	59,4	58,4	71,1	182,9	51,3	14,7	4	1020GV
1025GV	7 470	4000	98	118	32	24,9	27,2	0,1814	212,7	155,2	71,6	130,6	154,9	21,8	71,6	73,7	86,4	217,7	65,3	16,3	5	1025GV
1030GV	12 100	3600	111	140	39	38,6	43,1	0,2722	239,7	183,9	86,1	152,4	180,3	21,8	83,8	87,9	101,6	247,7	79,8	16,3	5	1030GV
1035GV	18 500	3100	134	163	51	61,2	68,0	0,4536	279,4	214,1	100,3	177,8	211,3	28,4	97,5	102,1	124,5	297,9	94,0	18,0	7	1035GV
1040GV	30 600	2800	160	196	64	93,0	102	0,6804	317,5	243,3	112,3	209,6	245,4	28,4	111,3	115,3	139,7	340,4	105,9	22,0	8	1040GV
1045GV	42 000	2600	183	216	77	129	138	0,9072	346,1	273,6	125,7	235,0	274,1	28,4	122,9	130,6	157,5	388,1	116,3	26,7	9	1045GV
1050GV	56 600	2400	200	235	89	184	197	1,36	388,9	309,6	144,0	254,0	305,8	38,1	140,7	147,3	175,3	423,7	134,6	27,7	8	1050GV
1055GV	74 000	2200	220	266	102	254	265	1,68	425,4	350,0	159,0	279,4	334,3	38,1	158,0	172,7	195,6	464,3	149,6	27,7	8	1055GV
1060GV	90 400	2100	244	290	115	...	390	2,27	457,2	385,6	177,8	304,8	366,0	25,4	169,2	186,4	221,0	522,2	168,1	30,9	8	1060GV
1070GV	135 000	1800	289	340	127	...	517	3,27	527,0	454,2	207,8	355,6	424,9	28,4	195,6	220,2	254,0	615,2	194,8	39,1	10	1070GV

★ See Page 15 for General Information and other Reference Notes.  
 † Torque Rating is for coupling only; refer to Page 22 for floating shaft selection and ratings.  
 ‡ Allowable speed listed is for GV52 coupling only; refer to Page 22 for floating shaft selection and running speed.

# Types G62, G63 & G66 Standard Flanged Sleeve Brakewheel/Disc Brake/Dimensions — Millimeters

Straight Bores — Wheel Sizes 177,8 Millimeters Diameter & Larger

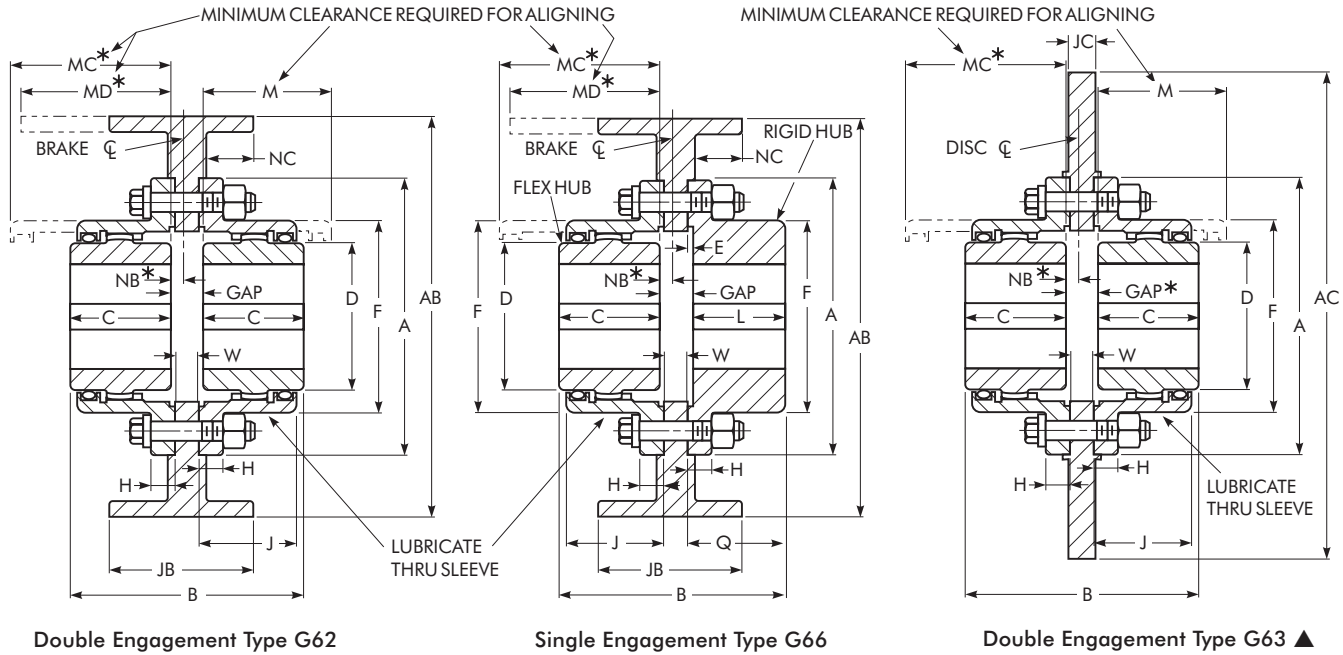

Brake wheel Size ♦	CPLG SIZE *	Brake Rating of Coupling (Nm)		Max Straight Bore (mm) •		Cplg Wt With No Bore-kg Less Wheel		Lube Wt (kg)		DIMENSIONS — Millimeters													Gap	
		Flex Hub	Rigid Hub	Min Bore (mm) ■	G62 G63	G66	G62 G63	G66	A	B		C	D	E	F	H	J	L	M	Q	W	G62 G63	G66	
										G62 G63	G66 With Sid Length Hubs													
177,8	1010G	251	50	65	13	4,54	4,54	0,0454	0,0272	115,9	98,6	96,3	42,9	68,6	2,5	83,8	14,0	38,9	39,6	51	42,2	9,7	13	14
203,2	1010G	569	65	80	10	9,07	9,07	0,0907	0,0544	152,4	114,3	112,3	49,3	86,4	2,5	105,2	19,0	47,8	46,2	61	48,8	12,7	16	17
244,3	1020G	1 050	78	98	26	15,9	15,9	0,1361	0,0907	177,8	139,7	137,2	62,0	105,2	2,5	126,5	19,0	59,4	58,4	76	61,0	12,7	16	17
289	1025G	1 897	98	118	32	29,5	27,2	0,2722	0,1588	212,7	173,0	169,7	77,0	130,6	2,5	154,9	21,8	71,6	73,7	91	76,2	14,2	19	19
320,5	1030G	3 117	111	140	39	43,1	43,1	0,4082	0,2268	239,7	201,4	198,1	91,2	152,4	2,5	180,3	21,8	83,8	87,9	107	90,4	14,2	19	19
371,3	1035G	4 810	134	163	51	68,0	68,0	0,5670	0,3402	279,4	238,3	233,2	106,4	177,8	2,5	211,3	28,4	97,5	102,1	130	104,6	19,0	25	25
428,7	1040G	7 317	160	196	64	97,5	99,8	0,9072	0,5443	317,5	266,7	261,9	120,6	209,6	4,1	245,4	28,4	111,3	115,3	145	119,4	19,0	25	26
457,2	1045G	10 027	183	216	77	136	136	1,1340	0,6350	346,1	296,7	292,1	134,9	235,0	4,1	274,1	28,4	122,9	130,6	165	134,6	19,0	27	27
492,2	1050G	13 550	200	235	89	191	195	1,8688	1,1340	388,9	339,6	334,5	153,2	254,0	5,1	305,8	38,1	140,7	147,3	183	152,4	25,4	33	34
530,3	1055G	17 784	220	266	102	249	263	2,3224	1,3608	425,4	369,8	374,9	168,1	279,4	5,1	334,3	38,1	158,0	172,7	203	177,8	25,4	33	34
584,2	1060G	23 035	244	290	115	306	324	3,4019	1,9278	457,2	409,4	410,5	188,2	304,8	6,6	366,0	25,4	169,2	186,4	229	193,0	25,4	33	36
660,4	1070G	33 469	289	340	127	485	508	4,4452	2,6082	527,0	476,3	479,0	220,7	355,6	8,4	424,9	28,4	195,6	220,2	267	228,6	25,4	35	38

★ See Page 15 for General Information and other Reference Notes.  
 ♦ Maximum rim velocity is 182,88 meters per minute. Brakewheel must be balanced if peripheral speed exceeds 182,88 meters per minute.  
 • Dimensions and allowable speed vary with application; consult the Factory.  
 ▲ Dimensions AC and JC depend upon customer caliper specifications.

# Types G62/G66 Standard Flanged Sleeve Brakewheel (for AISE Brakes)/Dimensions — Millimeters

Taper Bores — Wheel Sizes 203,2 Millimeters – 762 Millimeters Diameter & Larger

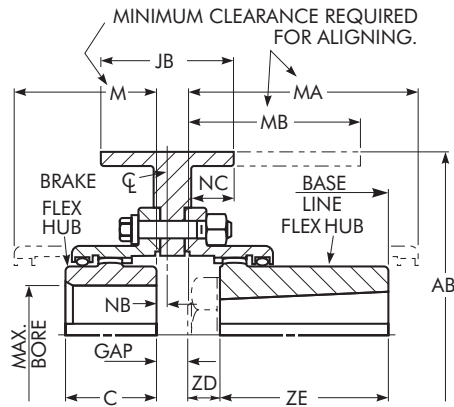

Double Engagement Type G62  
(One Hub Taper Bored)  
Figure 1

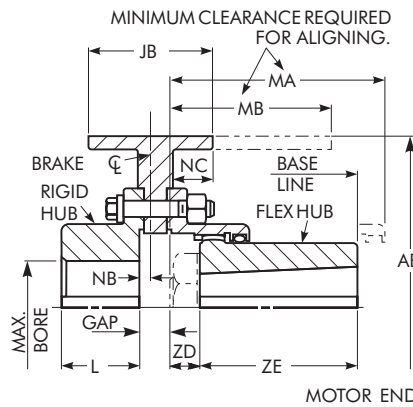

Single Engagement Type G66  
(Flex Hub Taper Bored)  
Figure 2

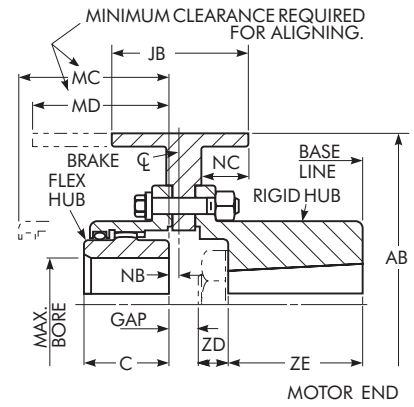

Single Engagement Type G66  
(Rigid Hub Taper and C' Bored)  
Figure 3

Brakewheel Dia x Face ♦ Dimensions (mm) AB x JB	Wheel Drawing No.	CPLG SIZE *	Mill Motor Size	Allow Speed rpm ▲	Brake Rating (Nm) ↓	Brake Manufacturer & Catalog Number				DIMENSIONS — Millimeters											
						C-H Co.	E.C. & M.	G.E.	West	C	L	M	MA MB Max	MC MD Max	NB		NC	ZD	ZE	Gap	
															Fig 1 & 3	Fig 2				Fig 1	Fig 2 & 3
203,2 x 82,6	330155	1015G	802	2860	136	8	T-08	A100	TM83	49,3	46,2	61,0	114,3	73,7	14,2	15,5	37,3	23,9	76,2	16	17
254,0 x 95,3	330156	1015G	803,804	2290	271	10	T-10	A101	TM1035	49,3	46,2	61,0	127,0	73,7	22,4	23,4	51,6	25,4	88,9	16	17
330,2 x 146,1	330158	1020G	806	1760	745	13	T-13	A102	TM1355	62,0	58,4	76,2	142,7	88,9	19,1	20,3	73,9	28,7	101,6	16	17
330,2 x 146,1	330159	1025G	808	1760	745	13	T-13	A102	TM1355	77,0	73,7	91,4	158,8	104,1	28,4	29,0	81,0	31,8	114,3	19	19
406,4 x 171,5	330160	1025G	810	1430	1 355	16	T-16	A103	TM1665	77,0	73,7	91,4	162,1	119,9	3,0*	3,6	68,3	35,1	114,3	19	19
482,6 x 222,3	330162	1030G	812	1200	2 710	19	T-19	A104	TM1985	91,2	87,9	106,7	177,8	149,4	6,4*	5,8	84,1	38,1	127,0	19	19
482,6 x 222,3	330163	1035G	816	1200	2 710	19	T-19	A104	TM1985	106,4	102,1	129,5	180,3	167,1	3,0	3,0	88,1	41,4	127,0	25	25
584,2 x 285,8	330164	1040G	818	995	5 420	23	T-23	A105	TM2311	120,6	115,3	144,8	208,3	198,6	0	12,7	116,6	44,5	139,7	25	27
584,2 x 285,8	330165	1040G	820	995	5 420	23	T-23	A105	TM2311	120,6	115,6	144,8	211,1	209,8	11,2*	9,9*	105,7	33,3	152,4	25	27
762 x 362	330166	1050G	822	765	12 195	30	...	...	...	153,2	147,3	182,9	215,9	270,0	11,2	9,4*	136,7	44,5	171,5	33	35
762 x 362	330167	1050G	824	765	12 195	30	...	...	...	153,2	147,3	182,9	244,3	247,9	4,8	6,4	152,4	60,2	184,2	33	35

\* See Page 15 for General Information and other Reference Notes.

♦ For standard AISE brakes.

▲ Based on maximum rim velocity of 182,88 meters per minute.

\* Symbol indicates that Dimension NB and the brakewheel centerline are to the left of the hub face.

# Type GL20 Standard Flanged Sleeve

## Slide Double Engagement/Dimensions — Millimeters

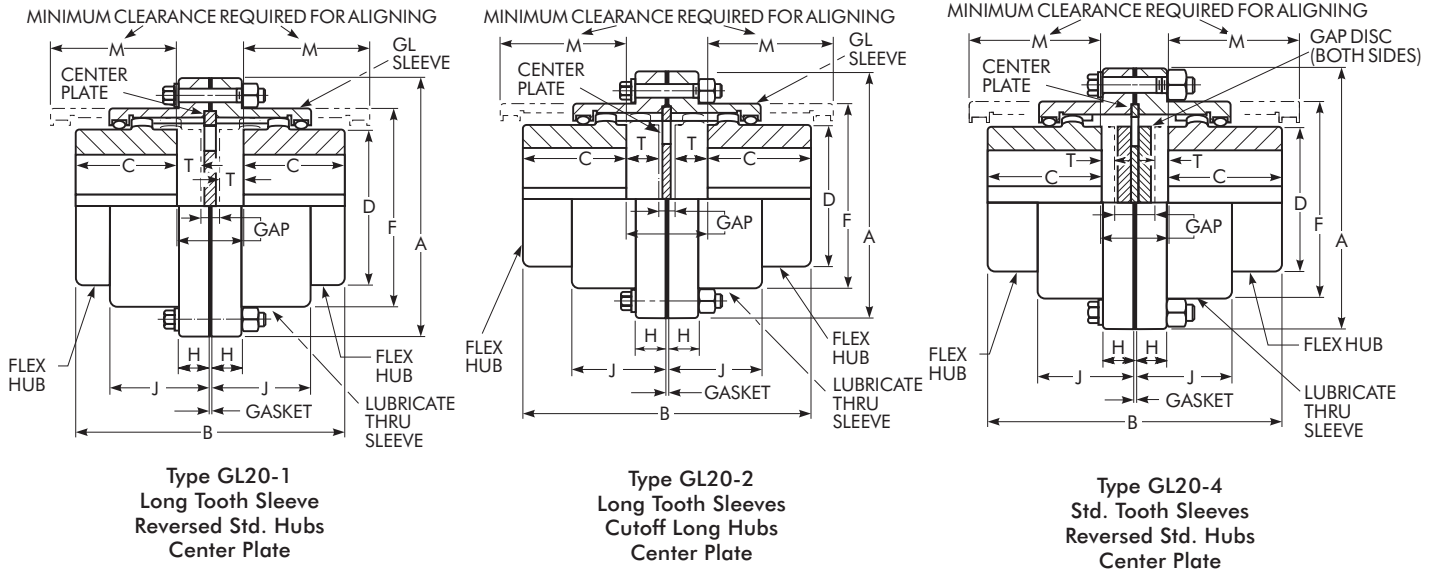

### Choosing an Assembly

Select the assembly that provides a Total "T" dimension from the table below equal to the application requirements.

- GL20-1 Moderate slide capacity, moderate price.
- GL20-2 Greatest slide capacity, highest price.
- GL20-4 Least slide capacity, lowest price.

SIZE ★	Torque Rating (Nm) †	Allow Speed rpm ‡	Max Bore (mm) •	Min Bore (mm) ▣	Cplg Wt With No Bore-kg	Lube Wt (kg)	DIMENSIONS — Millimeters						SIZE ★
							A	C	D	F	H	J	
1010GL	1 140	5300	50	13	4,54	0,0227	115,9	42,9	68,6	83,8	14,0	38,9	1010GL
1015GL	2 350	4300	65	20	9,07	0,0363	152,4	49,3	86,4	105,2	19,0	47,8	1015GL
1020GL	4 270	3700	78	26	15,9	0,0635	177,8	62,0	105,2	126,5	19,0	59,4	1020GL
1025GL	7 470	3300	98	32	29,5	0,1134	212,7	77,0	130,6	154,9	21,8	71,6	1025GL
1030GL	12 100	2900	111	39	40,8	0,1814	239,7	91,2	152,4	180,3	21,8	83,8	1030GL
1035GL	18 500	2600	134	51	68,0	0,2722	279,4	106,4	177,8	211,3	28,4	97,5	1035GL
1040GL	30 600	2400	160	64	99,8	0,4536	317,5	120,6	209,6	245,4	28,4	111,3	1040GL
1045GL	42 000	2100	183	77	136	0,5080	346,1	134,9	235,0	274,1	28,4	122,9	1045GL
1050GL	56 600	1900	200	89	193	0,9072	388,9	153,2	254,0	305,8	38,1	140,7	1050GL
1055GL	74 000	1800	220	102	254	0,1314	425,4	168,1	279,4	334,3	38,1	158,0	1055GL
1060GL	90 400	1600	244	115	318	0,5876	457,2	188,2	304,8	366,0	25,4	169,2	1060GL
1070GL	135 000	1400	289	127	499	1,1772	527,0	220,7	355,6	424,9	28,4	195,6	1070GL

SIZE	DIMENSIONS — Millimeters																	
	Type GL20-1						Type GL20-2						Type GL20-4					
	B Max	M	T (Max)		Gap		B Max	M	T (Max)		Gap		B Max	M	T (Max)		Gap	
			Each	Total	Min	Max			Each	Total	Min	Max			Each	Total	Min	Max
1010GL	96,3	53,8	12,7	2,5	8	10	126,2	58,4	16,3	32,5	8	40	96,3	53,8	2,0	4,3	6	10
1015GL	127,3	59,7	10,4	20,8	8	29	152,7	68,6	23,1	46,2	8	54	127,3	59,7	7,4	15,0	14	29
1020GL	150,6	77,2	9,0	18,8	8	27	186,2	83,8	27,2	54,4	8	62	150,6	77,2	9,9	20,1	7	27
1025GL	187,7	93,5	12,2	24,4	9	34	231,4	101,6	34,0	68,1	9	78	187,7	93,5	6,1	12,4	21	34
1030GL	227,3	108,2	17,8	35,6	9	45	263,4	91,4	35,8	71,6	9	81	227,3	108,2	11,4	23,1	22	45
1035GL	273,6	124,5	24,6	49,3	11	61	314,7	104,1	45,2	90,4	11	102	273,6	124,5	14,0	27,9	33	61
1040GL	320,3	138,7	32,3	64,5	15	79	362,5	119,4	53,3	106,7	15	121	320,3	138,7	16,3	32,5	47	79
1045GL	355,3	154,4	34,8	69,6	16	86	405,6	129,5	59,9	119,9	16	136	355,3	154,4	19,3	38,6	47	86
1050GL	408,2	175,5	41,9	83,8	18	102	459,5	149,9	67,6	135,1	18	153	408,2	175,5	20,6	41,4	61	102
1055GL	470,2	190,8	57,9	115,8	18	134	510,3	167,6	78,0	156,0	18	174	470,2	190,8	21,1	42,2	92	134
1060GL	503,7	211,6	53,1	106,2	21	127	563,1	182,9	82,8	165,6	21	187	503,7	211,6	24,6	49,5	78	127
1070GL	591,8	245,4	62,0	124,0	26	150	664,5	210,8	98,3	196,6	26	223	591,8	245,4	26,9	54,1	96	150

★ See Page 15 for General Information and other Reference Notes.  
 ◆ Gap discs are not required for Sizes 1010 and 1020GL.

# Type GL52 Standard Flanged Sleeve

## Slide Single Engagement/Dimensions — Millimeters

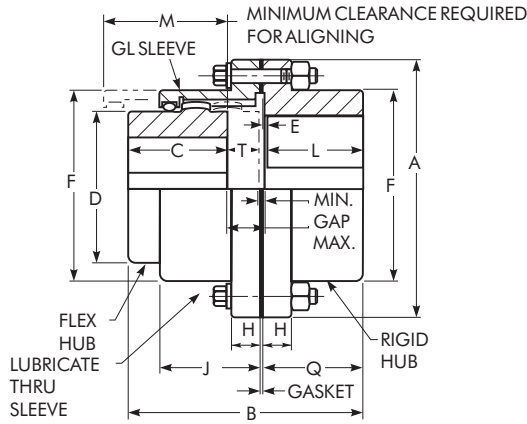

Type GL52-1 Long Tooth Sleeve  
Reversed Std. Hub

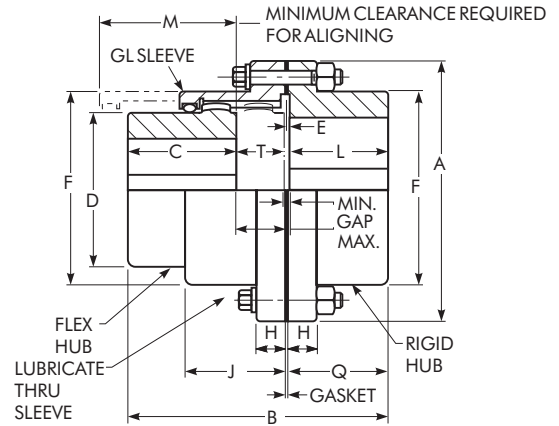

Type GL52-2 Long Tooth Sleeve  
Cutoff Long Hub

### Choosing an Assembly

Select the assembly that provides a Total "T" dimension from the table below equal to the application requirements.

GL52-1 — Moderate slide capacity, moderate price.

GL52-2 — Greatest slide capacity, highest price.

SIZE ★	Torque Rating (Nm) †	Allow Speed rpm ‡	Max Bore (mm) •		Min Bore (mm) ■	Cplg Wt With No Bore (kg)	Lube Wt (kg)	DIMENSIONS — Millimeters									SIZE ★
			Flex Hub	Rigid Hub				A	C	D	E	F	H	J	L	Q	
1010GL	1 140	5300	50	65	13	4,54	0,0136	115,9	42,9	68,6	2,5	83,8	14,0	38,9	39,6	42,2	1010GL
1015GL	2 350	4300	65	80	20	9,07	0,0227	152,4	49,3	86,4	2,5	105,2	19,0	47,8	46,2	48,8	1015GL
1020GL	4 270	3700	78	98	26	15,9	0,0363	177,8	62,0	105,2	2,5	126,5	19,0	59,4	58,4	61,0	1020GL
1025GL	7 470	3300	98	118	32	29,5	0,0635	212,7	77,0	130,6	2,5	154,9	21,8	71,6	73,7	76,2	1025GL
1030GL	12 100	2900	111	140	39	43,1	0,1134	239,7	91,2	152,4	2,5	180,3	21,8	83,8	87,9	90,4	1030GL
1035GL	18 500	2600	134	163	51	68,0	0,1814	279,4	106,4	177,8	2,5	211,3	28,4	97,5	102,1	104,6	1035GL
1040GL	30 600	2400	160	196	64	99,8	0,2722	317,5	120,6	209,6	4,1	245,4	28,4	111,3	115,3	119,4	1040GL
1045GL	42 000	2100	183	216	77	136	0,3402	346,1	134,9	235,0	4,1	274,1	28,4	122,9	130,6	134,6	1045GL
1050GL	56 600	1900	200	235	89	195	0,5443	388,9	153,2	254,0	5,1	305,8	38,1	140,7	147,3	152,4	1050GL
1055GL	74 000	1800	220	266	102	263	0,7257	425,4	168,1	279,4	5,1	334,3	38,1	158,0	172,7	177,8	1055GL
1060GL	90 400	1600	244	290	115	324	0,9616	457,2	188,2	304,8	6,6	366,0	25,4	169,2	186,4	193,0	1060GL
1070GL	135 000	1400	289	340	127	510	1,3608	527,0	220,7	355,6	8,4	424,9	28,4	195,6	220,2	228,6	1070GL

★ See Page 15 for General Information and Reference Notes

SIZE ★	DIMENSIONS — Millimeters									
	Type GL52-1					Type GL52-2				
	B Max	M	T Max	Gap		B Max	M	T Max	Gap	
Min				Max	Min				Max	
1010GL	90,2	53,8	3,6	4	8	105,2	58,4	18,5	4	23
1015GL	112,3	59,7	12,7	4	17	125,0	68,6	25,4	4	30
1020GL	136,1	84,8	11,7	4	16	153,9	83,8	29,5	4	34
1025GL	169,7	93,5	14,5	5	19	191,8	101,6	36,3	5	41
1030GL	204,0	108,2	20,1	5	25	222,0	91,4	38,1	5	43
1035GL	241,3	124,5	27,2	6	33	261,9	104,1	47,8	6	53
1040GL	279,4	138,7	36,3	7	43	300,5	119,4	57,4	7	65
1045GL	314,7	154,4	38,9	8	47	337,8	129,5	64,0	8	72
1050GL	356,1	175,5	47,0	9	56	381,8	149,9	72,6	9	81
1055GL	412,5	190,8	63,0	9	72	432,6	167,6	83,1	9	92
1060GL	444,8	211,6	59,7	10	70	474,5	182,9	89,4	10	100
1070GL	524,0	245,4	70,4	13	83	560,3	210,8	106,7	13	119

# Type G70

## Disconnect (Inching Drives)/Dimensions — Millimeters

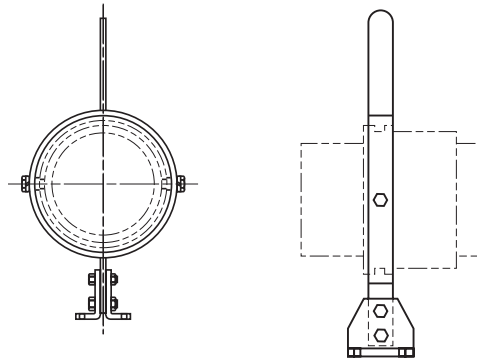
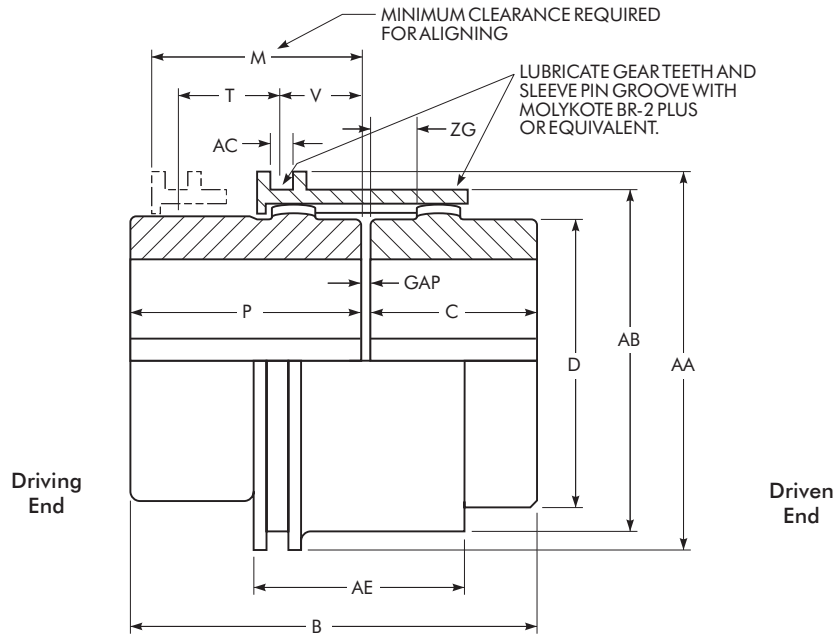

Optional hand operated shifter mechanism to shift and secure the proper position of the sleeve assembly.

SIZE ★	Torque Rating (Nm) †	Allow Speed rpm ‡	Max Bore (mm) •	Min Bore (mm) ▫	Cplg Wt With No Bore (kg)	DIMENSIONS — Millimeters													SIZE ★
						B	C	D	M	P	T	V	AA	AB	AC	AE	ZG	Gap	
1010G	1 140	630	50	13	4,08	115,8	42,9	68,6	69,6	69,6	30,0	21,8	97,0	83,8	8,1	59,9	14,7	3	1010G
1015G	2 350	500	65	20	6,80	120,9	49,3	86,4	68,6	68,6	29,5	21,3	120,9	107,4	8,1	58,9	12,7	3	1015G
1020G	4 270	400	78	26	13,6	152,9	62,0	105,2	87,9	87,9	38,1	29,0	145,8	129,5	11,2	78,2	17,8	3	1020G
1025G	7 470	330	98	32	24,0	188,5	77,0	130,6	106,7	106,7	48,3	37,6	172,7	156,5	11,2	97,0	21,8	5	1025G
1030G	12 100	280	111	39	36,3	215,9	91,2	152,4	119,9	119,9	54,9	42,7	201,2	181,9	14,2	110,2	24,4	5	1030G
1035G	18 500	240	134	51	55,8	246,4	106,4	177,8	133,6	133,6	63,0	48,3	231,1	212,1	14,2	124,0	26,9	6	1035G
1040G	30 600	200	160	64	83,0	269,7	120,6	209,6	142,7	142,7	67,6	52,8	269,2	250,2	14,2	133,1	27,4	6	1040G
1045G	42 000	180	183	77	118,8	305,8	134,9	235,0	163,1	163,1	77,2	59,9	298,2	275,6	17,3	153,4	31,5	8	1045G
1050G	56 600	170	200	89	160,1	338,8	153,2	254,0	177,8	177,8	84,3	67,1	331,2	308,9	17,3	167,6	34,8	8	1050G
1055G	74 000	150	220	102	199,1	356,6	168,1	279,4	180,3	180,3	85,9	68,1	356,6	334,3	17,3	170,2	32,8	8	1055G
1060G	90 400	140	244	115	273,5	406,9	188,2	304,8	210,8	210,8	100,1	81,8	396,7	366,0	19,3	201,2	42,4	8	1060G
1070G	135 000	120	289	127	424,1	466,3	220,7	355,6	238,8	236,2	116,8	93,2	455,7	424,9	19,3	229,4	49,8	10	1070G

★ See Page 15 for General Information and Reference Notes.

# Type G72

## Disconnect/Dimensions — Millimeters

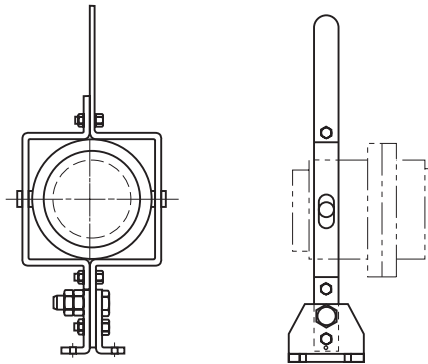
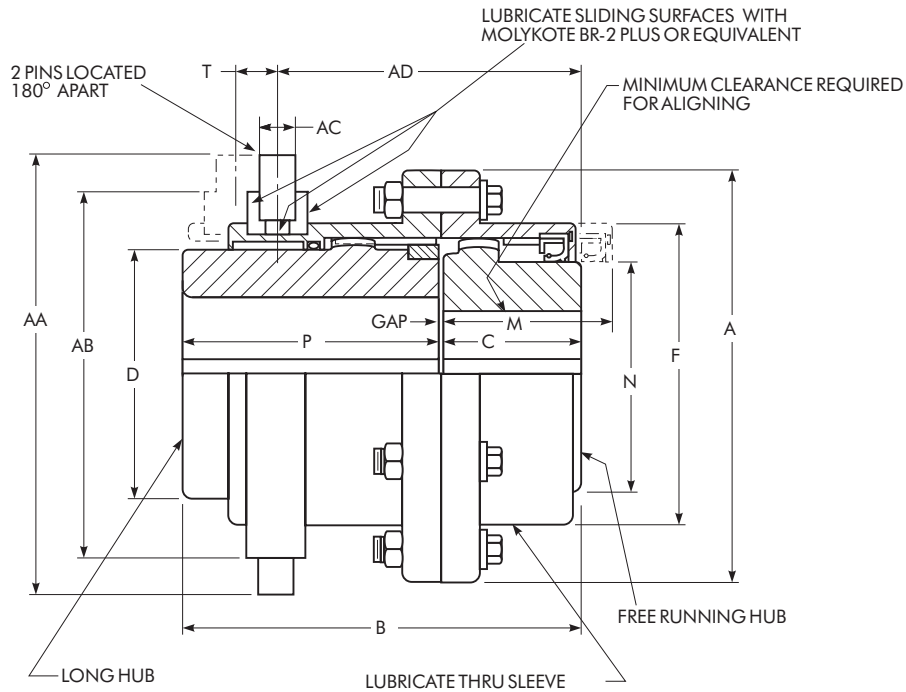

Optional hand operated shifter mechanism to shift and secure the proper position of the sleeve assembly.

SIZE *	Torque Rating (Nm) †	Allow Speed rpm ‡	Max Bore (mm) •		Min Bore (mm) ▯	Cplg Wt With No Bore (kg)	Lube Wt (kg)	DIMENSIONS — Millimeters													SIZE *	
			Long Hub	Free Hub				A	B	C	D	F	M	N	P	T	AA	AB	AC	AD		Gap
1010G	1 140	4200	50	38	13	6,80	0,0318	115,9	128,5	42,7	68,6	83,8	58,4	57,2	82,6	12,7	158,8	127,0	15,7	93,5	3	1010G
1015G	2 350	3200	65	52	20	13,2	0,0544	152,4	147,6	52,3	86,4	105,2	76,2	76,2	91,9	14,2	184,2	152,4	15,7	108,2	3	1015G
1020G	4 270	2450	78	68	26	22,7	0,0907	177,8	179,3	62,0	105,2	126,5	83,8	98,6	114,3	22,4	196,8	165,1	15,7	136,7	3	1020G
1025G	7 470	2000	98	83	32	35,8	0,1724	212,7	214,4	73,2	130,6	154,9	91,4	120,7	136,7	22,4	228,6	190,5	19,1	165,1	5	1025G
1030G	12 100	1650	111	102	39	52,2	0,2722	239,7	245,9	98,6	152,4	180,3	106,7	146,1	142,7	25,4	247,6	215,9	22,4	199,6	5	1030G
1035G	18 500	1530	134	110	51	81,6	0,4082	279,4	276,4	101,6	177,8	211,3	104,1	158,8	168,1	28,4	301,8	269,7	22,4	219,5	6	1035G
1040G	30 600	1200	160	141	64	121	0,6804	317,5	306,1	112,3	209,6	245,4	124,5	203,2	187,5	31,8	352,6	295,1	25,4	245,4	6	1040G
1045G	42 000	1060	183	157	77	152	0,7711	346,1	314,5	122,4	235,0	274,1	139,7	225,6	184,2	39,6	393,7	330,2	25,4	251,7	8	1045G
1050G	56 600	950	200	187	89	209	1,3608	388,9	360,4	142,7	254,0	305,8	182,9	254,0	209,6	44,5	381,0	323,8	25,4	283,5	8	1050G
1055G	74 000	860	220	187	102	278	1,6783	425,4	385,8	168,1	279,4	334,3	184,2	254,0	209,6	53,8	450,9	400,0	28,4	338,1	8	1055G
1060G	90 400	830	244	219	115	367	2,3814	457,2	465,1	180,8	304,8	366,0	193,5	292,1	276,4	50,8	463,6	422,1	28,4	369,8	8	1060G
1070G	135 000	680	289	276	127	524	3,2659	527,0	479,6	196,9	355,6	424,9	266,7	355,6	273,0	57,2	584,2	508,0	28,4	383,0	10	1070G

★ See Page 15 for General Information and Reference Notes.

# Type GP20/52/82 Standard Flanged Sleeve

## Insulated/Dimensions — Millimeters

Type GP20 Double Engagement Coupling

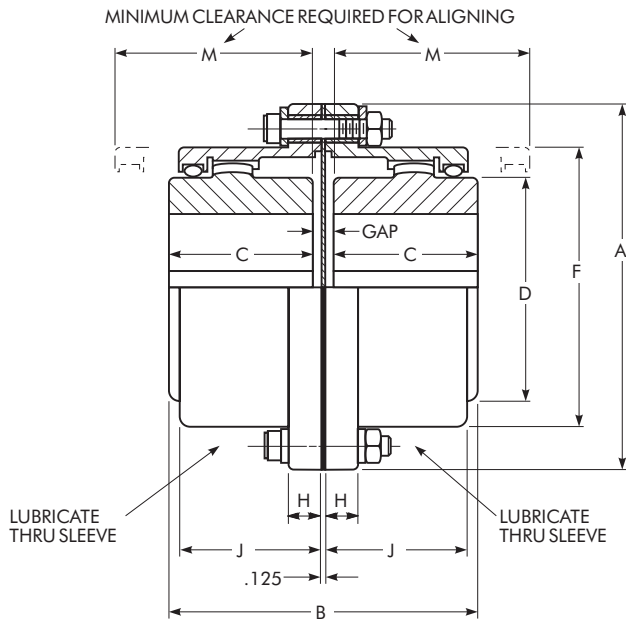

Type GP52 Single Engagement Coupling

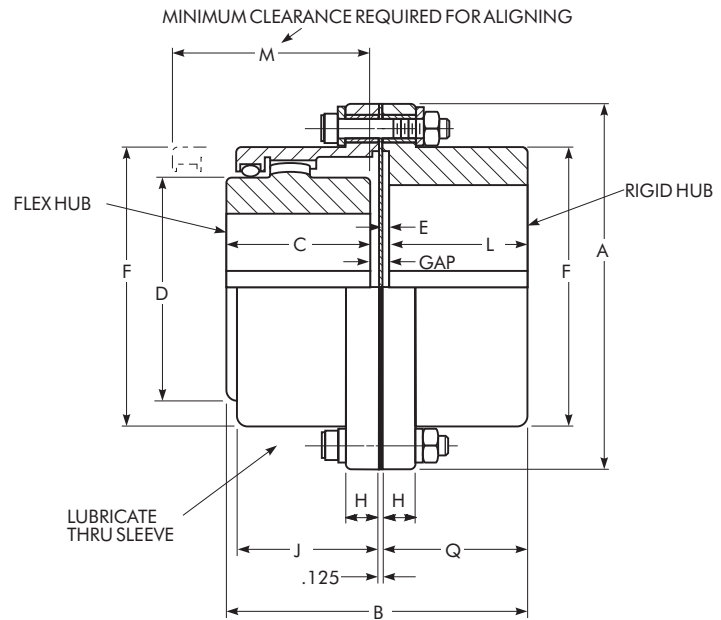

SIZE ★	Torque Rating (Nm) †	Allow Speed rpm ‡	Max Bore (mm) •		Min Bore (mm) ■	Cplg Wt With No Bore-kg			Lube Wt-kg	
			Flex Hub	Rigid Hub		GP20	GP52	GP82	GP20	GP52
1025G	7 470	5000	98	118	32	29,5	27,2	27,2	0,2268	0,1179
1030G	12 100	4400	111	140	39	43,1	43,1	43,1	0,3629	0,1814
1035G	18 500	3900	134	163	51	68,0	68,0	70,3	0,5443	0,2722
1040G	30 600	3600	160	196	64	97,5	99,8	102,1	0,9072	0,4672
1045G	42 000	3200	183	216	77	136,1	136,1	140,6	1,04	0,5670
1050G	56 600	2900	200	235	89	190,5	195,0	204,1	1,77	0,9072
1055G	74 000	2650	220	266	102	249,5	263,1	281,2	2,22	1,13
1060G	90 400	2450	244	290	115	306,2	324,3	335,7	3,18	1,70
1070G	135 000	2150	289	340	127	485,3	508,0	535,2	4,35	2,27

★ See Page 15 for General Information and other Reference Notes.

Type GP82 Rigid Coupling

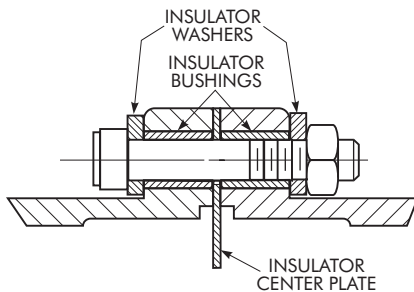
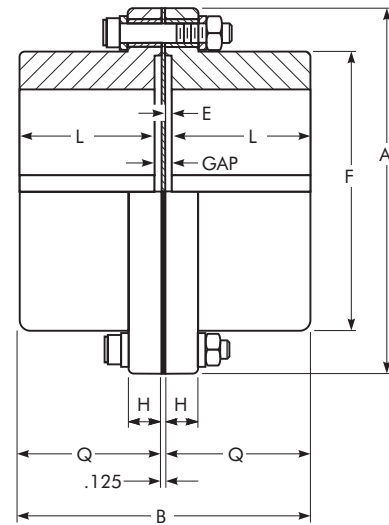

SIZE ★	Flange Bolt		DIMENSIONS — Millimeters															SIZE ★	
			A	B			C	D	E	F	H	J	L	M	Q	Gap			
	GP20	GP52		GP82	GP20	GP52										GP82			
1025GP	.500-13 x 3.00	47,5	212,7	162,1	158,5	155,4	77,0	130,6	2,5	154,9	21,8	71,6	73,7	91,4	76,2	8	9	9	1025GP
1030GP	.500-13 x 3.00	47,5	239,7	190,2	186,9	183,9	91,2	152,4	2,5	180,3	21,8	83,8	87,9	106,7	90,4	8	9	9	1030GP
1035GP	.625-11 x 4.00	94,9	279,4	222,2	217,2	212,3	106,4	177,8	2,5	211,3	28,4	97,5	102,1	129,5	104,6	10	9	9	1035GP
1040GP	.625-11 x 4.00	94,9	317,5	251,0	245,9	241,8	120,6	209,6	4,1	245,4	28,4	111,3	115,3	144,8	119,4	10	11	12	1040GP
1045GP	.625-11 x 4.00	94,9	346,1	280,9	276,1	272,3	134,9	235,0	4,1	274,1	28,4	122,9	130,6	165,1	134,6	11	11	12	1045GP
1050GP	.750-10 x 5.00	163	388,9	317,2	312,2	307,8	153,2	254,0	5,1	305,8	38,1	140,7	147,3	182,9	152,4	11	12	14	1050GP
1055GP	.750-10 x 5.00	163	425,4	347,5	352,6	358,6	168,1	279,4	5,1	334,3	38,1	158,0	172,7	203,2	177,8	11	12	14	1055GP
1060GP	.750-10 x 4.00	163	457,2	387,1	388,1	389,1	188,2	304,8	6,6	366,0	25,4	169,2	186,4	228,6	193,0	11	14	17	1060GP
1070GP	.875-9 x 4.50	203	527,0	454,4	456,7	460,2	220,7	355,6	8,4	424,9	28,4	195,6	220,2	266,7	228,6	13	16	20	1070GP



# Type G82 Standard Flanged Sleeve

## Rigid/Dimensions — Millimeters

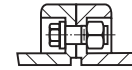
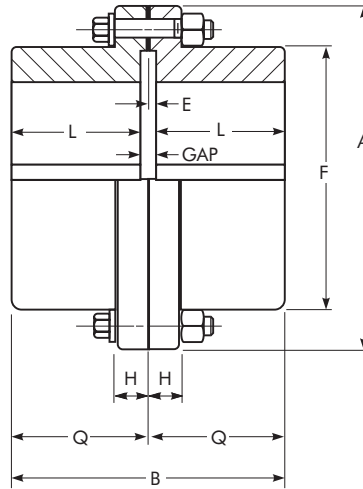

Type G81 Shrouded Bolts furnished only when specified on order. Sizes 1060G and 1070G available only as Type G82.

SIZE ★	Torque Rating (Nm) †	Allow Speed rpm ‡	Max Bore (mm) •	Min Bore (mm) ■	Cplg Wt With No Bore-kg		DIMENSIONS — Millimeters								SIZE ★
					G81	G82	A	B	E	F	H	L	Q	Gap	
<b>1010G</b>	1 140	8000	65	13	4,08	4,54	115,9	84,3	2,5	83,8	14,0	39,6	42,2	5	<b>1010G</b>
<b>1015G</b>	2 350	6500	80	20	8,62	9,07	152,4	97,5	2,5	105,2	19,0	46,2	48,8	5	<b>1015G</b>
<b>1020G</b>	4 270	5600	98	26	13,6	15,9	177,8	121,9	2,5	126,5	19,0	58,4	61,0	5	<b>1020G</b>
<b>1025G</b>	7 470	5000	118	32	24,9	27,2	212,7	152,4	2,5	154,9	21,8	73,7	76,2	5	<b>1025G</b>
<b>1030G</b>	12 100	4400	140	39	40,8	43,1	239,7	180,8	2,5	180,3	21,8	87,9	90,4	5	<b>1030G</b>
<b>1035G</b>	18 500	3900	163	51	61,2	70,3	279,4	209,3	2,5	211,3	28,4	102,1	104,6	5	<b>1035G</b>
<b>1040G</b>	30 600	3600	196	64	95,3	102	317,5	238,8	4,1	245,4	28,4	115,3	119,4	8	<b>1040G</b>
<b>1045G</b>	42 000	3200	216	77	132	141	346,1	269,2	4,1	274,1	28,4	130,6	134,6	8	<b>1045G</b>
<b>1050G</b>	56 600	2900	235	89	188	204	388,9	304,8	5,1	305,8	38,1	147,3	152,4	10	<b>1050G</b>
<b>1055G</b>	74 000	2650	266	102	268	281	425,4	355,6	5,1	334,3	38,1	172,7	177,8	10	<b>1055G</b>
<b>1060G</b>	90 400	2450	290	115	...	336	457,2	386,1	6,6	366,0	25,4	186,4	193,0	13	<b>1060G</b>
<b>1070G</b>	135 000	2150	340	127	...	535	527,0	457,2	8,4	424,9	28,4	220,2	228,6	17	<b>1070G</b>

★ Refer to Page 15 for General Information and Reference Notes.

# Type GV82 Standard Flanged Sleeve

## Rigid Thrust/Dimensions — Millimeters

Type GV82 couplings are used as rigid connections for the low speed shaft of a gear drive and a mixer shaft or suspended load. The coupling carries the torque load, weight of the shaft and impeller, thrust forces and resulting bending moments.

When a rigid coupling is required, the following additional information is necessary.

1. Required thrust capacity and direction of thrust.
2. Radial force at impeller.
3. Distance from the center of coupling fastener flange to the center of the impeller.
4. Weight of shaft and impeller.

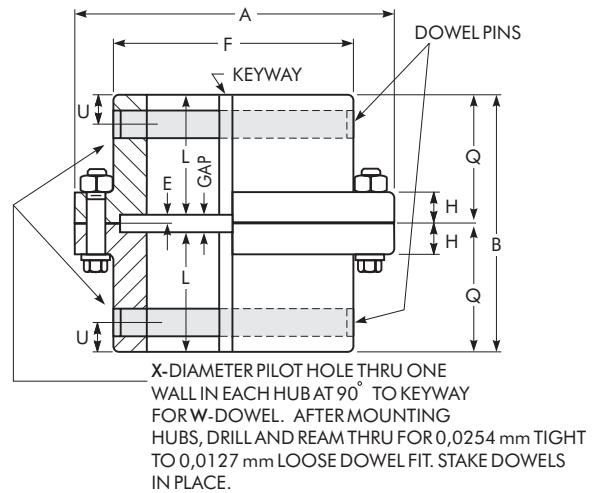
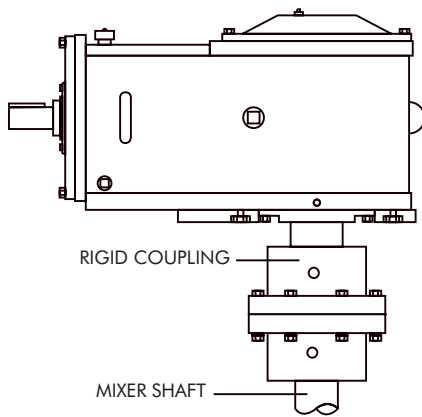

SIZE ★	Torque Rating (Nm) †	Hub Bore Range (mm) •	Cplg Wt With No Bore-kg	DIMENSIONS — Millimeters												SIZE ★
				A	B	E	F	H	L	Q	U	W		X	Gap	
												Dowel Dia x Length	Dowel Hole-Dia + .0,0127 - .0,0000			
1010GV	1 140	34,9 – 57,2	4,5	115,9	84,3	2,5	83,8	14,0	39,6	42,2	9,7	9,5 x 81,8	9,5	8,7	5	1010GV
1015GV	2 350	41,3 – 69,8	9,1	152,4	97,5	2,5	105,2	19,0	46,2	48,8	12,7	12,7 x 103,1	12,7	11,9	5	1015GV
1020GV	4 270	63,5 – 82,6	15,9	177,8	121,9	2,5	126,5	19,0	58,4	61,0	19,1	19,1 x 124,0	19,0	18,3	5	1020GV
1025GV	7 470	82,6 – 101,6	27,2	212,7	152,4	2,5	154,9	21,8	73,7	76,2	25,4	25,4 x 151,9	25,4	23,8	5	1025GV
1030GV	12 100	88,9 – 114,3	43,1	239,7	180,8	2,5	180,3	21,8	87,9	90,4	28,4	28,6 x 176,8	28,5	27,0	5	1030GV
1035GV	18 500	101,6 – 133,4	70,3	279,4	209,3	2,5	211,3	28,4	102,1	104,6	31,8	31,8 x 208,3	31,7	30,2	5	1035GV
1040GV	30 600	114,3 – 158,8	102	317,5	238,8	4,1	245,4	28,4	115,3	119,4	35,1	34,9 x 241,8	34,9	33,4	8	1040GV
1045GV	42 000	127,0 – 177,8	141	346,1	269,2	4,1	274,1	28,4	130,6	134,6	38,1	38,1 x 270,3	38,1	36,5	8	1045GV
1050GV	56 600	146,0 – 196,8	204	388,9	304,8	5,1	305,8	38,1	147,3	152,4	44,5	44,4 x 301,2	44,4	42,9	10	1050GV
1055GV	74 000	146,0 – 215,9	281	425,4	355,6	5,1	334,3	38,1	172,7	177,8	44,5	44,4 x 330,2	44,4	42,9	10	1055GV
1060GV	90 400	171,4 – 235,0	336	457,2	386,1	6,6	366,0	25,4	186,4	193,0	50,8	50,8 x 361,2	50,8	49,2	13	1060GV
1070GV	135 000	171,4 – 273,1	535	527,0	457,2	8,4	424,9	28,4	220,2	228,6	50,8	50,8 x 420,6	50,8	49,2	17	1070GV

★ Refer to Page 15 for General Information and other Reference Notes.

◆ Dowels: diameters, +0,000,-0,025 mm material, AISI 4140 hardness, 310-350HB; furnished by the Factory. Customer is responsible for checking and furnishing driven shaft with satisfactory capacity.

### OTHER AXIAL RETENTION OPTIONS — AVAILABLE ON TYPE GXVF (Refer to the Factory)

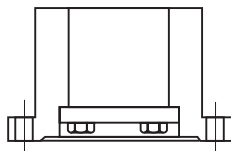

KEEPER PLATE

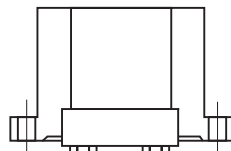

REGISTERED KEEPER PLATE

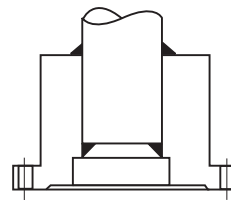

WELDED

# Type GR20 Standard Flanged Sleeve

## Shear Pin/Double Engagement Dimensions — Millimeters

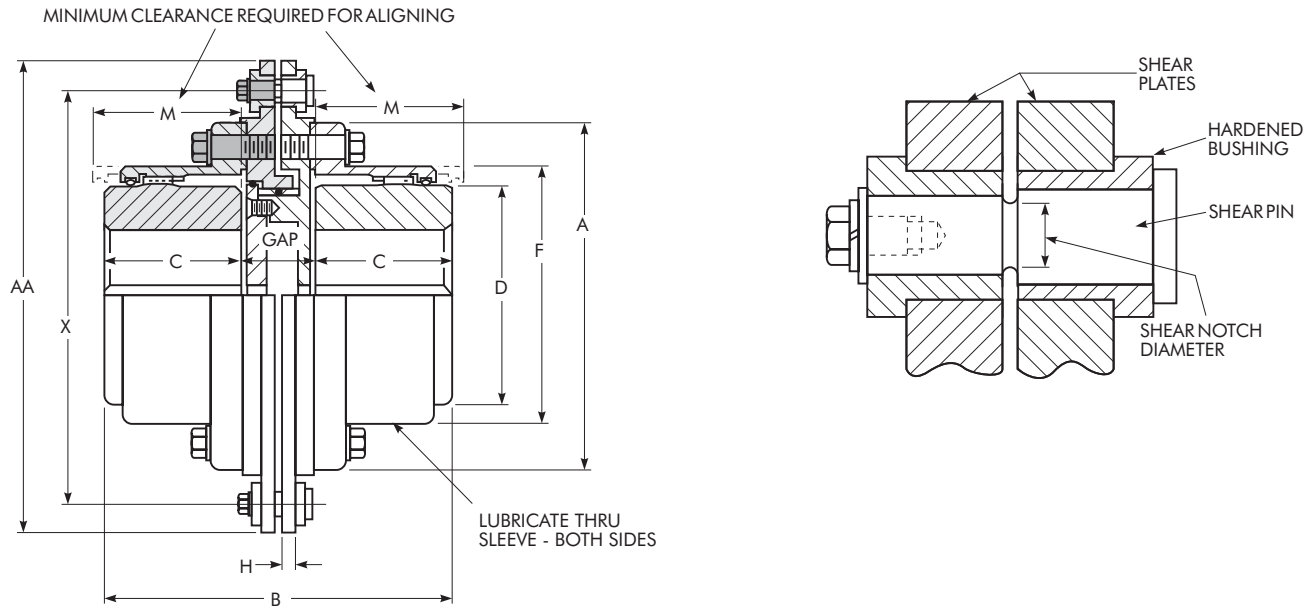

SIZE ★	Torque Rating (Nm) †	Shear Torque (Nm)		Allow Speed rpm ‡	Cplg Wt With No Bore-kg	Lube Wt (kg)	DIMENSIONS — Millimeters										SIZE ★
		Min	Max				A	B	C	D	F	H	M	X	AA	Gap	
1010GR	1 140	124	1 073	5000	8,62	0,0408	115,9	121,7	42,9	68,6	83,8	9,1	50,8	147,6	173,0	36	1010GR
1015GR	2 350	282	2 407	4000	15,0	0,0726	152,4	138,2	49,3	86,4	105,2	9,1	61,0	184,2	209,6	40	1015GR
1020GR	4 270	599	4 452	3600	28,1	0,1134	177,8	170,2	62,0	105,2	126,5	12,2	76,2	209,6	235,0	46	1020GR
1025GR	7 470	1 062	8 011	2700	49,0	0,2268	212,7	201,7	77,0	130,6	154,9	12,2	91,4	266,7	317,5	48	1025GR
1030GR	12 100	1 774	13 344	2400	66,2	0,3629	239,7	234,2	91,2	152,4	180,3	12,2	106,7	293,7	338,1	52	1030GR
1035GR	18 500	2 542	20 462	2100	102	0,5443	279,4	273,3	106,4	177,8	211,3	12,2	129,5	333,4	377,8	60	1035GR
1040GR	30 600	3 141	31 139	1900	138	0,9072	317,5	301,8	120,6	209,6	245,4	12,2	144,8	371,5	415,9	60	1040GR
1045GR	42 000	5 435	42 708	1800	185	1,0433	346,1	330,2	134,9	235,0	274,1	12,2	165,1	400,0	450,8	60	1045GR
1050GR	56 600	6 982	57 837	1750	279	1,7690	388,9	394,5	153,2	254,0	305,8	24,9	182,9	438,2	482,6	88	1050GR
1055GR	74 000	8 926	75 632	1500	362	2,2226	425,4	424,4	168,1	279,4	334,3	24,9	203,2	482,6	533,4	88	1055GR
1060GR	90 400	12 575	100 139	1400	441	3,1751	457,2	464,6	188,2	304,8	366,0	24,9	228,6	520,7	590,8	88	1060GR
1070GR	135 000	18 044	142 429	1250	670	4,3545	527,0	529,6	220,7	355,6	424,9	24,9	266,7	590,6	660,4	88	1070GR

★ Refer to Page 15 for General Information and other Reference Notes. Minimum and maximum bores are the same as those for G20, Page 19.

**TABLE 8 — Shear Pin Design Criteria**

SIZE	Shear Torque (Nm)			
	2- Pin Design		4- Pin Design	
	Minimum	Maximum	Minimum	Maximum
1010GR	124	427	428	1 073
1015GR	282	960	962	2 407
1020GR	599	1 780	1 781	4 452
1025GR	1 062	3 203	3 204	8 011
1030GR	1 774	5 339	5 340	13 344
1035GR	2 542	8 186	8 187	20 462
1040GR	3 141	12 457	12 458	31 139
1045GR	5 435	17 083	17 084	42 708
1050GR	6 982	23 134	23 135	57 837
1055GR	8 926	30 257	30 258	75 632
1060GR	12 575	40 053	40 054	100 139
1070GR	18 044	56 944	56 945	142 429

# Type G Standard Flanged Sleeve

## Mill Motor & Taper Bores/Metric Equivalent Dimensions — Millimeters

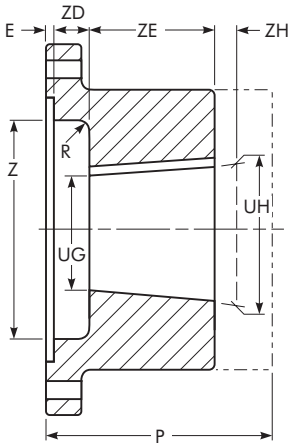
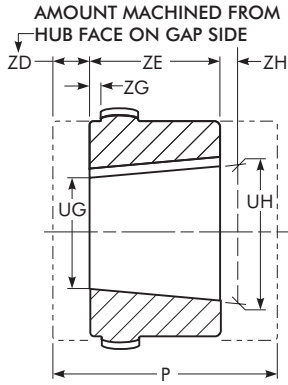

**TABLE 9 — Standard AISE AC & DC Mill Motor Coupling Selections**

Motor Frame Sizes			COUPLING SIZE *	E (mm)	R (mm)	UG (mm)	UH (mm)	Keyway (mm)	Z (mm)	ZD (mm)	ZE (mm)	ZG (mm)	ZH (mm)
2 602	802 A, B & C	AC 1, 2 & 4	1015G	2,5	7,9	36,5	44,4	12,7 x 6,4	82,6	23,9	76,2	1,5	0,6
			1020G	2,5								5,6	
			1025G	2,5								12,4	
603 604	803 804	...	1015G	2,5	9,7	41,5	50,8	12,7 x 6,4	85,7	25,4	88,9	0,0	0,7
			1020G	2,5								4,1	
			1025G	2,5								10,9	
			1030G	2,5								19,1	
606	806	AC 8 & 12	1020G	2,5	9,7	52,9	63,5	12,7 x 6,4	101,6	28,4	101,6	1,0	0,7
			1025G	2,5								7,6	
			1030G	2,5								15,7	
			1035G	2,5								25,4	
608	808	...	1025G	2,5	12,7	64,3	76,2	19,0 x 6,4	133,4	31,8	114,3	4,6	0,7
			1030G	2,5								12,7	
			1035G	2,5								22,4	
			1040G	4,1								32,0	
610	810	AC180	1025G	2,5	12,7	70,6	82,6	19,0 x 6,4	142,9♦	35,1	114,3	1,3	0,9
			1030G	2,5								9,7	
			1035G	2,5								19,3	
			1040G	4,1								29,0	
612	812	AC 25 & 30	1030G	2,5	12,7	78,8	92,1	19,0 x 6,4	158,8	38,1	127,0	6,4	0,9
			1035G	2,5								16,0	
			1040G	4,1								25,7	
			1045G	4,1								32,3	
614	814	AC 40 & 50	1035G	2,5	12,7	94,7	108,0	25,4 x 9,5	174,6	41,1	127,0	12,7	0,9
			1040G	4,1								22,6	
			1045G	4,1								29,2	
			1050G	5,1								40,6	
616	816	...	1035G	2,5	15,7	102,9	115,8 *	31,8 x 9,5	195,3	44,4	123,7 *	9,7	0,9
			1040G	4,1								19,3	
			1045G	4,1								25,9	
			1050G	5,1								37,1	
			1050G	5,1								37,1	
618	818	...	1040G	4,1	15,7	111,1	127,0	31,8 x 12,7	212,7	33,5	152,4	30,5	1,0
			1045G	4,1								37,3	
			1050G	5,1								48,5	
620	820	...	1045G	4,1	19,0	131,4	149,2	38,1 x 19,0	247,6	44,4	171,4	25,9	1,0
			1050G	5,1								37,3	
			1055G	5,1								51,3	
622	822	...	1045G	4,1	19,0	139,6	158,8	38,1 x 19,0	247,6	60,2	184,2	10,2	1,0
			1050G	5,1								21,6	
			1055G	5,1								35,3	
			1060G	6,6								41,7	
624	824	...	1050G	5,1	19,0	153,3	177,8	38,1 x 19,0	247,6	60,2	235,0	21,3	1,0
			1055G	5,1								35,3	
			1060G	6,6								41,7	
			1060G	6,6								41,7	
			1070G	8,4								59,7	

\* See Page 15 for General Information and other Reference Notes. Minimum coupling selections are based on coupling bore capacity. Check coupling rating for all selections. Refer to Pages 19 & 21 for coupling dimensions.

♦ Spanner wrench required for Size 1025G.

\* For rigid hub only.

**TABLE 10 — Taper and Counterbore Limitations/Metric Equivalent Dimensions — Millimeters ▲**

SIZE *	Flex Hub					Rigid Hub					SIZE *
	P Max *	UG Min	UH Max ▼	ZD Max	ZE Min	P Max *	UG Min	UH Max ▼	ZD Max	ZE Min	
1010G	101,6	12,7	50	18,5	42,9	104,1	12,7	65	76,2	39,6	1010G
1015G	114,3	19,0	65	25,4	49,3	116,8	19,0	80	85,9	46,2	1015G
1020G	130,0	25,4	78	29,5	62,0	132,6	25,4	98	101,6	58,4	1020G
1025G	149,4	31,8	98	36,3	77,0	151,9	31,8	118	142,7	73,7	1025G
1030G	165,1	38,1	111	44,4	91,2	167,6	38,1	140	158,8	87,9	1030G
1035G	184,2	50,8	134	54,1	106,4	170,7	50,8	163	174,8	102,1	1035G
1040G	203,2	63,5	160	63,8	120,6	191,0	63,5	196	212,9	114,3	1040G
1045G	244,3	76,2	183	70,4	134,9	249,4	76,2	216	247,6	129,5	1045G
1050G	295,1	88,9	200	81,8	153,2	300,2	88,9	235	273,0	147,3	1050G
1055G	298,4	101,6	220	95,8	168,1	303,3	101,6	266	298,5	172,7	1055G
1060G	304,8	114,3	244	102,1	188,2	311,2	114,3	290	330,2	186,4	1060G
1070G	309,9	127,0	289	120,1	220,7	312,9	127,0	340	381,0	220,2	1070G

▲ This table specifies the taper bore limitations for the usual requirements. For hubs longer than those listed, refer to the Factory.

♦ Standard Long Hub length, consult the Factory for longer lengths.

▼ Keyway for keys shown in Table 11, Page 37.

# Engineering Data — Standard Flanged Sleeve & Continuous Sleeve

**TABLE 11 — Recommended Commercial Keys for Bores with One Key — Millimeters & Inches**

MILLIMETERS (Per ISO R773 Standard)											
Shaft Diameter		Key	Shaft Diameter		Key	Shaft Diameter		Key	Shaft Diameter		Key
Over	Through		Over	Through		Over	Through		Over	Through	
6	8	2 x 2	38	44	12 x 8	95	110	28 x 16	260	290	63 x 32
8	10	3 x 3	44	50	14 x 9	110	130	32 x 18	290	330	70 x 36
10	12	4 x 4	50	58	16 x 10	130	150	36 x 20	330	380	80 x 40
12	17	5 x 5	58	65	18 x 11	150	170	40 x 22	380	440	90 x 45
17	22	6 x 6	65	75	20 x 12	170	200	45 x 25	440	500	100 x 50
22	30	8 x 7	75	85	22 x 14	200	230	50 x 28	...	...	...
30	38	10 x 8	85	95	25 x 14	230	260	56 x 32	...	...	...

INCHES (Per ANSI B17.1 Standard)											
Shaft Diameter		Key	Shaft Diameter		Key	Shaft Diameter		Key	Shaft Diameter		Key
Over	Through		Over	Through		Over	Through		Over	Through	
.438	.562	.125 x .125	1.750	2.250	.500 x .500	4.500	5.500	1.250 x 1.250	11.000	13.000	3.000 x 2.000
.562	.875	.188 x .188	2.250	2.750	.625 x .625	5.500	6.500	1.500 x 1.500	13.000	15.000	3.500 x 2.500
.875	1.250	.250 x .250	2.750	3.250	.750 x .750	6.500	7.500	1.750 x 1.500	15.000	18.000	4.000 x 3.000
1.250	1.375	.312 x .312	3.250	3.750	.875 x .875	7.500	9.000	2.000 x 1.500	18.000	22.000	5.000 x 3.500
1.375	1.750	.375 x .375	3.750	4.500	1.000 x 1.000	9.000	11.000	2.500 x 1.750	...	...	...

**TABLE 12 — Shaft Diameters & Ratings for NEMA 60 Hertz & 50 Hertz Metric Motors**

50 HERTZ METRIC MOTORS (kW)																		
Frame Size	80	90S	90L	100L	112M	132S	132M	160M	160L	180M	180L	200M/L	225S	225M	250S	250M	280S	280M
Shaft Diameter	19	24	24	28	28	38	38	42	42	48	48	55	55 60	55 60	60, 65 70	60, 65 70	65, 75 80	65, 75 80
3000 RPM	0,75 1,10	1,5	2,2	3,0	4	5,5 7,5		11 15	18,5	22		30 37	45	45	55	55 75	75 90	90 110
1500 RPM	0,55 0,75	1,1	1,5	2,2 3,0	4	5,5	7,5	11	15	18,5	22	30	37 45	45	55	55 75	75 90	90 110
1000 RPM	0,37 0,55	0,75	1,1	1,5	2,2	3	4 5,5	7,5	11		15	18,5 22	30	30	37	37 45	45 50	55 75
750 RPM	0,18 0,25	0,37	0,55	0,75 1,1	1,5	2,2	3	4 5,5	7,5		11	15	18,5	22	30	30 37	37 45	45 55

NEMA 60 HERTZ MOTORS (hp)																													
Frame Size	T Frames																TS Frames												
	143	145	182	184	213	215	254	256	284	286	324	326	364	365	404	405	444	445	284	286	324	326	364	365	404	405	444	445	
Shaft Diameter	.88	.88	1.13	1.13	1.38	1.38	1.63	1.63	1.88	1.88	2.13	2.13	2.38	2.38	2.88	2.88	3.38	3.38	1.63	1.63	1.88	1.88	1.88	1.88	2.13	2.13	2.38	2.38	
3600 RPM	Drip Proof	1 1/2	2-3	5	7 1/2	10	15	20	25	30	40	50	60	75	100	125	150	200	250	30	40	50	60	75	100	125	150	200	250
	Enclosed	1 1/2	2	3	5	7 1/2	10	15	20	25	30	40	50	60	75	...	100	125	150	25	30	40	50	60	75	...	100	125	150
1800 RPM	Drip Proof	1	1 1/2-2	3	5	7 1/2	10	15	20	25	30	40	50	60	75	100	125	150	200	25	30	40	50	60	75	100	125	150	200
	Enclosed	1	1 1/2-2	3	5	7 1/2	10	15	20	25	30	40	50	60	75	...	100	125	150	25	30	40	50	60	75	...	100	125	150
1200 RPM	Drip Proof & Enclosed	3/4	1	1 1/2	2	3	5	7 1/2	10	15	20	25	30	40	50	60	75	100	125	15	20	25	30	40	50	60	75	100	125
900 RPM	Drip Proof & Enclosed	1/2	3/4	1	1 1/2	2	3	5	7 1/2	10	15	20	25	30	40	50	60	75	100	10	15	20	25	30	40	50	60	75	100

# Engineering Data — Standard Flanged Sleeve & Continuous Sleeve

**TABLE 13 — Type G & GC Flex/Pilot Hub & Maximum Bores — Millimeters & Inches**

SIZE ★	MILLIMETERS — Fits Per Table 12				INCHES										
	Min Bore ■	Max. Bore °			With One Square Key			With One Rectangular Key					Max. Bore °		
		Std Bore Fits Per Table 15	Int Fit w/Setscrew Over Keyway	With Puller Holes Per Table 17	Max Bore •	Y=X		Max Bore •	Y = X		Max Bore •	Y=W/2		Int Fit w/ Setscrew Over Keyway	With Puller Holes Per Table 17
						W	X		W	X		W	X		
1010G/GC	13	50	45	38	1.875	.500	.250	2.000	.500	.187	2.125	.500	.125	1.750	1.500
1015G/GC	20	65	60	54	2.375	.625	.312	2.500	.625	.218	2.750	.625	.125	2.250	2.125
1020G/GC	26	78	75	72	2.875	.750	.375	3.125	.750	.250	3.250	.750	.125	2.750	2.875
1025G/GC	32	98	88	92	3.625	.875	.437	3.875	1.000	.375	4.000	1.000	.250	3.250	3.625
1030G/GC	39	111	101	104	4.125	1.000	.500	4.375	1.000	.375	4.750	1.250	.250	3.750	4.125
1035G/GC	51	134	121	124	4.875	1.250	.625	5.250	1.250	.437	5.750	1.500	.250	4.500	4.875
1040G	64	160	150	146	5.750	1.500	.750	6.250	1.500	.500	6.500	1.500	.250	5.500	5.750
1045G	77	183	160	171	6.500	1.500	.750	6.750	1.750	.750	...	...	...	5.750	6.750
1050G	89	200	177	187	7.000	1.750	.875	7.375	1.750	.750	...	...	...	6.500	7.375
1055G	102	220	200	209	7.750	2.000	1.000	8.250	2.000	.750	...	...	...	7.500	8.250
1060G	115	244	212	232	8.750	2.000	1.000	9.125	2.500	.875	...	...	...	8.000	9.125
1070G	127	289	235	276	10.000	2.500	1.250	10.875	2.500	.875	...	...	...	9.000	10.875

**TABLE 14 — Type G & GC Rigid Hub Maximum Bores — Millimeters & Inches**

SIZE ★	MILLIMETERS — Fits Per Table 12				INCHES										
	Min Bore ■	Max Bore °			With One Square Key			With One Rectangular Key					Max. Bore °		
		Std Bore Fits Per Table 15	Int Fit w/Setscrew Over Keyway	With Puller Holes Per Table 17	Max Bore •	Y=X		Max Bore •	Y = X		Max Bore •	Y=W/2		Int Fit w/ Setscrew Over Keyway	With Puller Holes Per Table 17
						W	X		W	X		W	X		
1010G	13	65	60	51	2.375	.625	.312	2.500	.625	.218	2.750	.625	.125	2.250	2.000
1015G	20	80	75	70	2.937	.750	.375	3.250	.750	.250	3.375	.875	.187	2.750	2.750
1020G	26	98	88	92	3.625	.875	.437	3.875	1.000	.375	4.000	1.000	.250	3.250	3.625
1025G	32	118	107	111	4.375	1.000	.500	4.625	1.250	.437	4.875	1.250	.250	3.875	4.375
1030G	39	140	121	130	5.125	1.250	.625	5.500	1.250	.437	5.875	1.500	.250	4.500	5.125
1035G	51	163	150	150	5.875	1.500	.750	6.500	1.500	.500	...	...	...	5.500	5.875
1040G	64	196	167	185	6.750	1.750	.875	7.250	1.750	.750	...	...	...	6.000	7.250
1045G	77	216	190	205	7.625	1.750	.875	8.125	2.000	.750	...	...	...	7.000	8.125
1050G	89	235	220	228	8.750	2.000	1.000	9.000	2.000	.750	...	...	...	8.250	9.000
1055G	102	266	230	250	9.750	2.000	1.000	10.000	2.500	.875	...	...	...	8.750	10.000
1060G	115	290	260	280	10.500	2.500	1.250	11.000	2.500	.875	...	...	...	9.750	11.000
1070G	127	340	290	330	12.000	3.000	1.500	13.000	3.000	1.000	...	...	...	11.000	13.000

★ See Page 15 for General Information and other Reference Notes.

■ Shaded areas indicate maximum bores for standard keys recommended in Table 11.

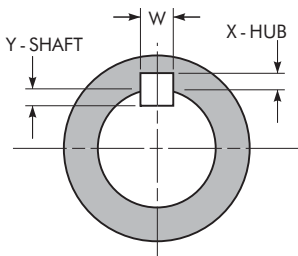

Check Key Stresses

**TABLE 15 — Recommended Bore Tolerances  
Falk Steel Coupling Hubs – Millimeters**

Shaft Diameter (ISO/R775-1969)		Bore Diameter Tolerance		
Nominal	Tolerance	Clearance	Transitional	Interference
6 to 30	j6/k6 ♦	F7	H7	M6
Over 30 to 50	k6	F7	H7	K6
Over 50 to 80	m6	F7	H7	K7
Over 80 to 100	m6	F7	H7	M7
Over 100 to 200	m6	F7	H7	P7
Over 200 to 355	m6	F7	H7	R7
Over 355 to 500	m6	F7	H7	R8

♦ Per DIN 748 — Differs with ISO/R775.

# Engineering Data — Standard Flanged Sleeve & Continuous Sleeve

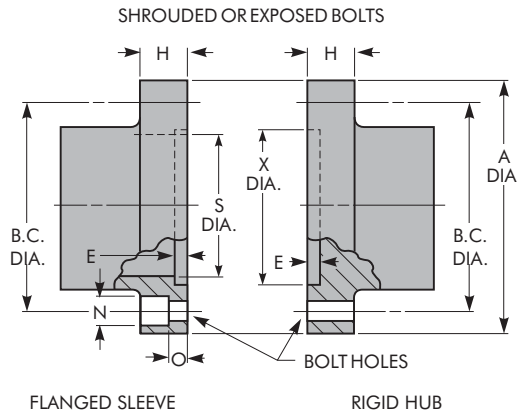
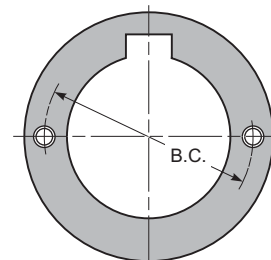

**TABLE 16 — Flanged Sleeve and Rigid Hub Details**

SIZE ★	Shrouded or Exposed Bolts - Millimeters					Shrouded				Exposed	
	A + 0,00- 0,10	E ± 0,25	H	S ± 0,25	X ± 0,25	B.C. (mm)	Bolt No.-Dia (in)	N (mm)	O (mm)	B.C. (mm)	Bolt No.-Dia (in)
1010G	115,87	2,54	14,0	77,72	80,77	95,25	6-250	11,7	6,35	95,25	6-250
1015G	152,40	2,54	19,0	96,77	99,57	122,22	8-375	14,7	6,35	122,22	8-375
1020G	177,80	2,54	19,0	117,86	121,92	147,62	10-375	14,7	6,35	149,23	6-500
1025G	212,73	2,54	19,0	144,78	148,84	177,80	10-500	19,8	8,13	180,98	6-625
1030G	239,73	2,54	21,8	169,16	173,22	203,20	12-500	19,8	8,13	206,38	8-625
1035G	279,40	2,54	21,8	195,33	199,64	235,74	12-625	24,6	10,16	241,30	8-750
1040G	317,50	4,06	28,4	230,12	234,95	269,88	14-625	24,6	10,16	279,40	8-750
1045G	346,08	4,06	28,4	255,52	260,35	298,45	14-625	24,6	10,16	304,80	10-750
1050G	388,95	5,08	38,1	280,92	290,07	334,98	14-750	29,5	14,22	342,90	8-875
1055G	425,45	5,08	38,1	307,09	315,47	366,73	16-750	29,5	14,22	368,30	14-875
1060G	457,20	6,60	25,4	337,31	353,57	...	...	...	...	400,05	14-875
1070G	527,05	8,38	25,4	388,62	404,88	...	...	...	...	463,55	16-1000

**TABLE 17 — Puller Bolt Holes (Conforms to API 610 Specs.)**

SIZE ★	B.C. — Millimeters		Tap Size UNC
	Flex Hub/Pilot Hub	Rigid Hub	
1010G/GC *	52,32	66,68	M10 x 1.5 x 13
1015G/GC *	69,85	85,73	M10 x 1.5 x 13
1020G/GC	88,90	107,95	M10 x 1.5 x 13
1025G/GC	112,78	133,10	M10 x 1.5 x 13
1030G/GC	128,52	156,46	M10 x 1.5 x 13
1035G/GC	152,40	182,37	M12 x 1.75 x 16
1040G	180,98	209,80	M16 x 2.0 x 20
1045G	200,03	233,17	M16 x 2.0 x 20
1050G	215,90	259,08	M20 x 2.5 x 22
1055G	238,13	284,48	M20 x 2.5 x 22
1060G	263,53	316,48	M20 x 2.5 x 22
1070G	311,15	368,30	M24 x 3.0 x 30



Puller bolt holes are available for an extra charge.

★ See Page 15 for General Information and other Reference Notes.

\* See Tables 13 and 14 for maximum bore limitation with puller holes.

# Engineering Data — Standard Flanged Sleeve & Continuous Sleeve

**TABLE 18 — Torsional Stiffness (x 10<sup>6</sup> Nm/Radian)**

SIZE ★	Exposed Bolt Types				Shrouded Bolt Types				Continuous Sleeve	
	Half Couplings		Complete Couplings		Half Couplings		Complete Couplings			
	Flex Half	Rigid Half	G20 GP20	G52 GP52	Flex Half	Rigid Half	G10	G51	GC02	GC05
1010G/GC	4,7	10,3	2,4	3,2	3,2	9,5	1,6	2,4	3,3	3,2
1015G/GC	12,1	24,1	6,0	8,0	8,9	21,2	4,4	6,2	6,8	6,7
1020G/GC	18,3	39,4	9,2	12,4	14,5	35,8	7,2	10,3	11,6	11,5
1025G/GC	27,8	69,0	13,9	20,0	22,3	62,9	11,2	16,5	21,9	22,0
1030G/GC	40,1	103,0	20,0	28,8	33,1	95,8	16,5	24,6	34,3	34,6
1035G/GC	53,0	169,6	26,4	40,3	56,0	154,9	28,0	41,1	48,9	49,9
1040G	108,8	268,5	54,3	77,4	78,9	241,6	39,4	59,4	...	...
1045G	138,2	355,2	69,0	99,4	114,9	332,4	57,4	85,4	...	...
1050G	222,1	477,5	111,1	151,6	177,7	457,8	88,8	128,0	...	...
1055G	244,9	607,3	122,4	175,6	220,8	564,3	110,4	158,6	...	...
1060G	292,4	743,9	146,2	209,8	...	...	...	...	...	...
1070G	483,1	1152,7	241,6	340,4	...	...	...	...	...	...

**TABLE 19 — WR<sup>2</sup> Values**

SIZE ★	Type G and GP KgM <sup>2</sup> (With No Bore)											Type GL		Type GV				Type GC	
	G10	G20 GP20	G32 <sup>†</sup>		Spacer * KgM <sup>2</sup> per mm	G51	G52 GP52	G70	G72	G81	G82 GP82 GV82	GL20	GL52	GV10	GV20	GV51	GV52	GC02	GC05
			Min. BE	Cplg. WR <sup>2</sup>															
1010G/GC	0,0047	0,0056	82,55	0,0102	0,0004	0,0050	0,0059	0,0032	0,0061	0,0050	0,0059	0,0059	0,0059	0,0047	0,0056	0,0050	0,0059	0,0030	0,0030
1015G/GC	0,0161	0,0205	82,55	0,0366	0,0005	0,0164	0,0208	0,0085	0,0225	0,0167	0,0214	0,0211	0,0211	0,0158	0,0202	0,0167	0,0211	0,0085	0,0088
1020G/GC	0,0360	0,0439	82,55	0,0717	0,0012	0,0380	0,0454	0,0234	0,0497	0,0395	0,0468	0,0454	0,0454	0,0366	0,0424	0,0380	0,0468	0,0225	0,0234
1025G/GC	0,0884	0,1127	95,25	0,1785	0,0023	0,0936	0,1170	0,0614	0,1244	0,0995	0,1229	0,1156	0,1185	0,0892	0,1127	0,0951	0,1185	0,0644	0,0658
1030G/GC	0,1697	0,2063	95,25	0,3175	0,0034	0,1814	0,2180	0,1317	0,2341	0,1931	0,2297	0,2165	0,2224	0,1697	0,2063	0,1829	0,2195	0,1369	0,1399
1035G/GC	0,3862	0,4755	120,65	0,7300	0,0078	0,4067	0,4960	0,2750	0,5208	0,4213	0,5164	0,4930	0,5033	0,3833	0,4725	0,4053	0,4989	0,2663	0,2712
1040G	0,7593	0,9085	120,65	1,32	0,0144	0,8003	0,9510	0,5764	0,9817	0,8339	0,9948	0,9539	0,9656	0,7549	0,9041	0,8047	0,9612	...	...
1045G	1,24	1,47	120,65	2,07	0,0258	1,31	1,52	1,01	1,51	1,37	1,57	1,54	1,54	1,23	1,46	1,32	1,53	...	...
1050G	2,20	2,63	146,05	3,87	0,0351	2,35	2,79	1,64	2,78	2,50	2,94	2,76	2,83	2,21	2,64	2,39	2,82	...	...
1055G	3,65	4,03	146,05	5,78	0,0465	3,97	4,39	2,40	4,18	4,28	4,74	4,23	4,45	3,65	4,04	4,01	4,44	...	...
1060G	...	5,33	146,05	6,61	0,0661	...	5,79	3,96	6,09	...	6,25	5,69	5,91	...	5,37	...	5,90	...	...
1070G	...	11,3	146,05	14,8	0,0971	...	12,3	8,29	11,8	...	13,3	12,0	12,5	...	11,4	...	12,5	...	...

- ★ See Page 15 for General Information and other Reference Notes.
- † To determine total WR<sup>2</sup> of spacer couplings with a BE (distance between shaft ends) greater than minimum:
  1. Subtract minimum BE from required BE.
  2. Multiply the result of Step 1 by the appropriate spacer WR<sup>2</sup> and add to coupling WR<sup>2</sup> at minimum BE.
- \* Values apply to the tube portion only. Flange WR<sup>2</sup> is included in the spacer WR<sup>2</sup> for minimum BE.

**TABLE 20 — Standard Filleted Keyways & Chamfered Keys — Millimeters**

Nominal Bore		Key			Hub Keyway				
Over	Thru	Size (Nominal)	Chamfer		Nominal Width *	Depth (T <sub>2</sub> ) <sup>■</sup>		Fillet Radius	
			Minimum	Maximum		Minimum	Maximum	Minimum	Maximum
12	17	5 x 5	0,25	0,40	5	2,3	2,4	0,16	0,25
17	22	6 x 6	0,25	0,40	6	2,8	2,9	0,16	0,25
22	30	8 x 7	0,25	0,40	8	3,3	3,5	0,16	0,25
30	38	10 x 8	0,40	0,60	10	3,3	3,5	0,25	0,40
38	44	12 x 8	0,40	0,60	12	3,3	3,5	0,25	0,40
44	50	14 x 9	0,40	0,60	14	3,8	4,0	0,25	0,40
50	58	16 x 10	0,40	0,60	16	4,3	4,5	0,25	0,40
58	65	18 x 11	0,40	0,60	18	4,4	4,6	0,25	0,40
65	75	20 x 12	0,60	0,80	20	4,9	5,1	0,40	0,60
75	85	22 x 14	0,60	0,80	22	5,4	5,6	0,40	0,60
85	95	25 x 14	0,60	0,80	25	5,4	5,6	0,40	0,60
95	110	28 x 16	0,60	0,80	28	6,4	6,6	0,40	0,60
110	130	32 x 18	0,60	0,80	32	7,4	7,6	0,40	0,60
130	150	36 x 20	1,00	1,20	36	8,4	8,7	0,70	1,00
150	170	40 x 22	1,00	1,20	40	9,4	9,7	0,70	1,00
170	200	45 x 25	1,00	1,20	45	10,4	10,7	0,70	1,00
200	230	50 x 28	1,00	1,20	50	11,4	11,7	0,70	1,00
230	260	56 x 32	1,60	2,00	56	12,4	12,7	1,20	1,60
260	290	63 x 32	1,60	2,00	63	12,4	12,7	1,20	1,60
290	330	70 x 36	1,60	2,00	70	14,4	14,7	1,20	1,60

- Standard keyway width tolerance is Js9.
- T<sub>2</sub> is from the top of the bore to the top of the hub keyway.

**Standard Filleted Keyways & Chamfered Keys**

Fillets are standard in metric keyways. If fillets are required in inch keyways, refer to Factory for recommendations.

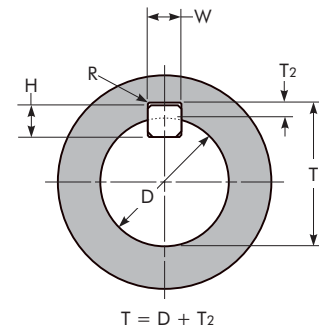



# Engineering Data — Standard Flanged Sleeve & Continuous Sleeve

**VARIABLE GAP** — Normally it is not necessary to overhang gear coupling hubs since the hubs can readily be reversed to produce different gap dimensions as illustrated in Figures 1, 2 and 4 below. Also, long hubs from Table 10, Page 36, can be cut off to suit required gap as illustrated in Figures 3 and 5 below.

However, when the distance between shafts is greater than the allowable coupling gap, overhang one or both hubs. It must be remembered that this practice reduces shaft-hub engagement. If the overhang with a standard hub results in less than .75 times the shaft diameter engagement, a coupling with long hubs is recommended. Use the standard interference fit and check key strength.

**CAUTION:** The effect of open keyways on coupling balance should always be considered.

If axial shaft movement is required, use the Type GL slide coupling.

**MISALIGNMENT CAPACITY** — Shaft misalignment can be due to the combined effects of both parallel and angular shaft displacement. Falk 1000 series gear couplings are designed to accommodate a static misalignment of 1-1/2° per gear mesh. The recommended installation misalignment is limited to 1/8° per gear mesh. Axial movement of connected shafts is also accommodated.

It is important that flexible couplings be properly aligned so that the maximum benefits of the equipment can be obtained. These benefits include the following:

1. Longer coupling life with minimum maintenance.
2. Longer life of the connected equipment as a result of reduced bending moments and radial forces which are related to the amount of misalignment.
3. Permit drive systems to have reserve misalignment capacity to accommodate unavoidable alignment changes caused by bearing wear foundation settling, thermal expansion, etc.

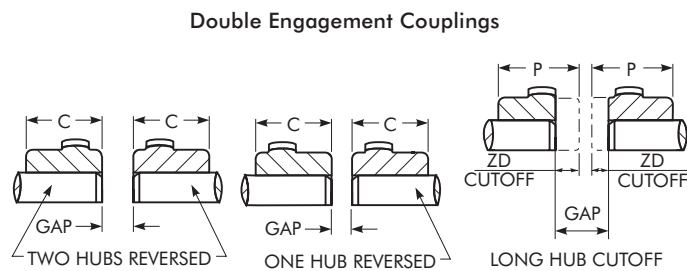

Figure 1

Figure 2

Figure 3

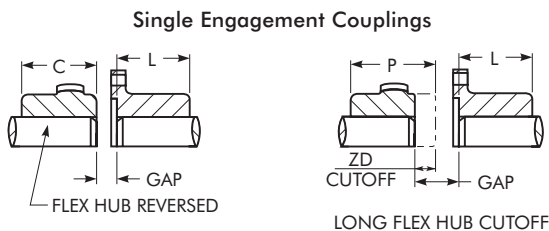

Figure 4

Figure 5

**TABLE 21 — Type G Only Variable Gap — Millimeters**

SIZE *	C Std	L Std	P Max	ZD Max †	Coupling Gap						
					Double Engagement			Single Engagement			
					Std	Fig 1	Fig 2	Fig 3	Std	Fig 4	Fig 5
1010G	42,9	39,6	101,6	18,5	3	10	7	40	4	8	23
1015G	49,3	46,2	114,3	25,4	3	29	16	54	4	17	29
1020G	62,0	58,4	130,0	29,5	3	27	15	62	4	16	33
1025G	77,0	73,7	149,4	36,3	5	34	19	77	5	19	41
1030G	91,2	87,9	165,1	44,4	5	45	25	94	5	25	49
1035G	106,4	102,1	184,2	54,1	6	61	34	115	6	33	60
1040G	120,6	115,3	203,2	63,8	6	61	43	134	7	44	71
1045G	134,9	130,6	244,3	70,4	8	86	47	149	8	47	78
1050G	153,2	147,3	295,1	81,8	8	102	55	172	9	56	91
1055G	168,1	172,7	298,4	95,8	8	134	71	199	9	72	105
1060G	188,2	186,4	304,8	102,1	8	127	68	212	10	70	112
1070G	220,7	220,2	309,9	120,1	10	150	80	250	13	83	133

\* See Page 15 for General Information and other Reference Notes.

† Standard gap must be increased by the amount cut off the hub, to maintain the correct flex hub tooth position.

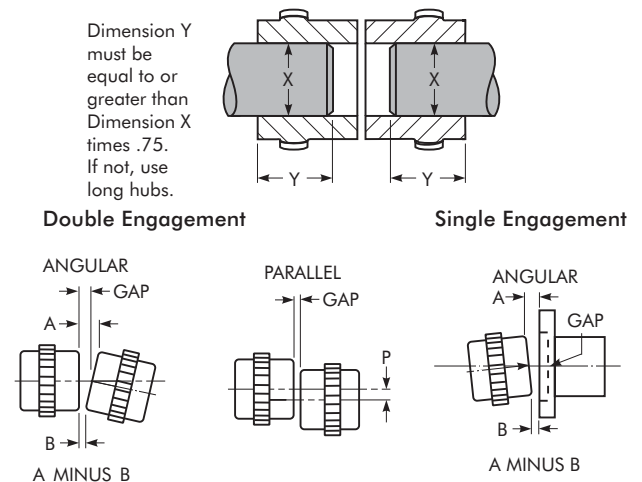

**TABLE 22 — Misalignment Capacity — Millimeters \***

SIZE *	Double Engagement				Single Engagement †	
	Recommended Installation Maximum		Maximum Operating *		Angular Maximum Millimeters	
	Parallel Offset-(mm) P	Angular (mm) A Minus B	Parallel Offset-(mm) P	Angular (mm) A Minus B	Recommended Installation A Minus B	Maximum Operating * A Minus B
1010G	0,05	0,15	0,66	1,80	0,15	0,89
1010GC	0,04	0,08	0,28	1,80	0,15	0,89
1015G	0,08	0,18	0,86	2,26	0,18	1,14
1015GC	0,04	0,18	0,43	2,26	0,18	1,14
1020G	0,08	0,23	1,02	2,74	0,23	1,37
1020GC	0,04	0,23	0,48	2,74	0,23	1,37
1025G	0,10	0,28	1,27	3,43	0,28	1,70
1025GC	0,05	0,28	0,61	3,43	0,28	1,70
1030G	0,13	0,33	1,52	3,99	0,33	2,01
1030GC	0,05	0,33	0,69	3,99	0,33	2,01
1035G	0,15	0,38	1,83	4,65	0,38	2,34
1035GC	0,08	0,33	0,81	4,65	0,38	2,34
1040G	0,18	0,46	2,13	5,49	0,46	2,74
1045G	0,20	0,51	2,39	6,15	0,51	3,07
1050G	0,23	0,56	2,72	6,65	0,56	3,33
1055G	0,28	0,61	3,12	7,32	0,61	3,66
1060G	0,28	0,66	3,35	7,98	0,66	3,99
1070G	0,33	0,79	3,94	9,32	0,79	4,65

\* These maximum operating alignment limits are each based on 3/4° per flex half coupling. Combined values of parallel and angular misalignment should not exceed 3/4°. Type GL slide couplings are limited to 1/4° per flex half.

† Do not use single engagement couplings to compensate for parallel offset misalignment.

# Type G20 Large Flanged Sleeve

## Double Engagement/Dimensions — Millimeters

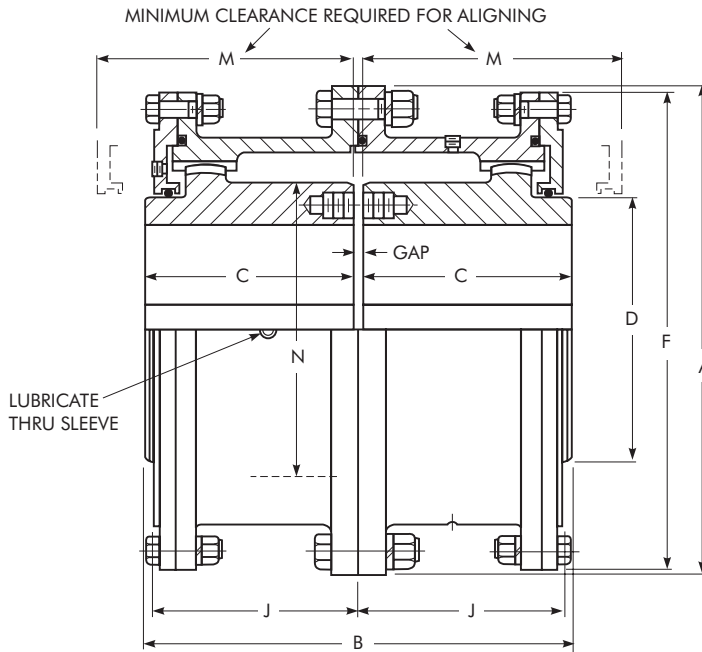

SIZE ★	Torque Rating (Nm) † (millions)		Allow Speed rpm ‡	Max. Bore (mm) •	Min Bore (mm) ■	Cplg Wt With No Bore (kg)	Lube Wt (kg)	DIMENSIONS — Millimeters								
	1000 Series	2000 Series						A	B	C	D	F	J	M	N	Gap
	1080/2080G	0,170						0,234	1750	266	101,60	703	9,5	590,6	508,5	249,2
1090/2090G	0,226	0,315	1550	290	114,30	984	12,2	660,4	565,4	276,4	393,7	641,4	265,2	327,2	419,1	13
1100/2100G	0,310	0,443	1450	320	127,00	1 302	15,0	711,2	622,3	304,8	444,5	698,5	293,6	355,6	469,9	13
1110/2110G	0,413	0,609	1330	373	139,70	1 678	17,7	774,7	679,2	333,2	495,3	749,3	322,3	384,0	520,7	13
1120/2120G	0,555	0,777	1200	400	152,40	2 114	20,9	838,2	717,8	352,6	546,1	825,5	341,4	403,4	571,5	13
1130/2130G	0,719	0,925	1075	440	165,10	2 595	32,7	911,4	761,7	371,3	584,2	886,0	362,0	434,8	609,6	19
1140/2140G	0,911	1,140	920	460	177,80	3 107	33,1	965,2	806,4	393,2	635,0	939,8	378,0	457,2	660,4	19
1150/2150G	1,100	1,350	770	490	190,50	3 765	40,8	1 028,7	857,2	419,1	685,8	1 003,3	407,9	482,6	711,2	19
1160/2160G	1,310	1,640	650	525 ♦♦	254,00	4 708	43,1	1 111,2	908,0	441,3	736,6	1 085,9	419,1	501,6	762,0 ♦	25
1180/2180G	1,660	2,140	480	600 ♦♦	285,75	6 260	49,9	1 219,2	939,8	457,2	838,2	1 193,8	434,8	520,7	863,6 ♦	25
1200/2200G	2,140	2,850	370	660 ♦♦	317,50	8 582	68,0	1 358,9	1 098,6	536,6	927,1	1 308,1	514,4	635,0	965,2 ♦	25
1220/2220G	2,720	3,560	290	725 ♦♦	349,25	11 685	107	1 511,3	1 193,8	584,2	1 016,0	1 473,2	565,2	685,8	1 066,8 ♦	25
1240/2240G	3,470	4,480	270	810 ♦♦	381,00	14 606	109	1 632,0	1 282,7	628,6	1 130,3	1 581,2	606,6	723,9	1 168,4 ♦	25
1260/2260G	4,490	5,480	250	880 ♦♦	412,75	17 799	122	1 746,2	1 371,6	673,1	1 231,9	1 695,4	647,7	774,7	1 270,0 ♦	25
1280/2280G	5,840	6,760	230	950 ♦♦	444,50	21 192	136	1 866,9	1 409,7	692,9	1 333,5	1 803,4	666,8	793,8	1 371,6 ♦	25
1300/2300G	6,760	8,190	220	1 025 ♦♦	476,25	24 807	150	1 974,8	1 447,8	711,2	1 435,1	1 911,4	685,8	800,1	1 473,2 ♦	25

★ See Page 15 for General Information and other Reference Notes.

♦ Reduced shank diameter hubs are available where required bore permits. See Table 31, Page 53 for selection.

• Note: There is no standardization of metric keys and keyways for bores greater than 500 mm.

Maximum bores for flex hubs 1150G and larger are based on a hub diameter to bore ratio of 1.4.

**TABLE 23 — Limited End Float & Standard Gap  
Disc Dimensions — Millimeters**

SIZE	B	End Float ▲	Gap Disc *		Gap
			Thickness	Diameter	
1080/2080G	517,1	4,78	16	416	18
1090/2090G	577,3	4,78	22	470	25
1100/2100G	634,2	4,78	22	521	25
1110/2110G	691,1	4,78	22	568	25
1120/2120G	729,7	4,78	22	622	25
1130/2130G	778,5	4,78	33	676	36
1140/2140G	822,2	4,78	33	727	36
1150/2150G	874,0	4,78	33	778	36

▲ If this value exceeds one-half rotor end float or equivalent manufacturer's specifications, refer to the Factory.

\* Gap disc material: Neoprene, 70 durometer.

# Type G52 Large Flanged Sleeve

## Single Engagement/Dimensions — Millimeters

**IMPORTANT** — When couplings are mounted on a floating shaft, do not exceed allowable shaft speed for the assembly. Use a gap disc in each coupling.

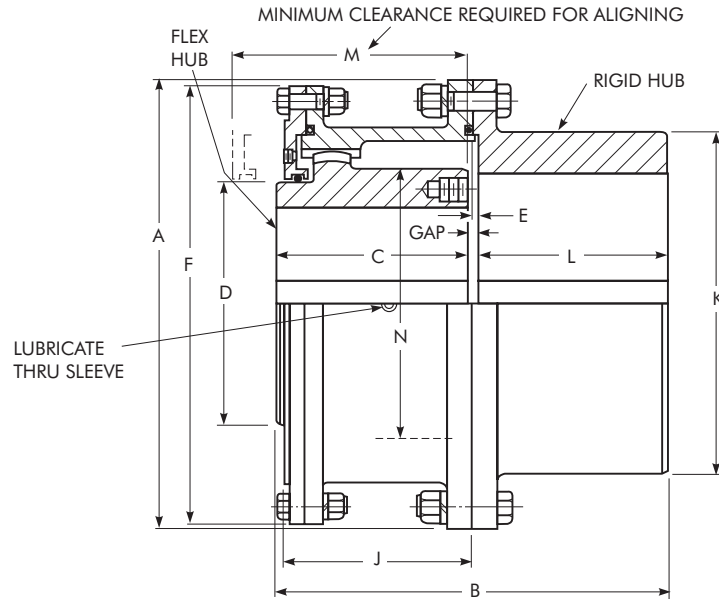

SIZE ★	Torque Rating (Nm) (millions) †		Allow Speed rpm ‡	Max Bore (mm) •		Min Bore (mm) ■	Cplg Wt With No Bore (kg)	Lube Wt (kg)	DIMENSIONS — Millimeters											
	1000 Series	2000 Series		Flex Hub	Rigid Hub				A	B	C	D	E	F	J	K*	L	M	N	Gap
	1080/2080G	0,170		0,234	1750				266	340	101,60	699	5	590,6	511,0	249,4	355,6	8,1	571,5	242,8
1090/2090G	0,226	0,315	1550	290	380	114,30	984	6	660,4	566,4	276,4	393,7	8,1	641,4	265,2	508,0	275,8	327,2	419,1	14
1100/2100G	0,310	0,443	1450	320	400	127,00	1 252	8	711,2	625,3	304,8	444,5	9,7	698,5	293,6	530,4	304,8	355,6	469,9	16
1110/2110G	0,413	0,609	1330	373	440	139,70	1 637	9	774,7	682,2	333,2	495,3	9,7	749,3	322,3	584,2	333,2	384,0	520,7	16
1120/2120G	0,555	0,777	1200	400	483	152,40	2 077	11	838,2	720,6	352,6	546,1	9,7	825,5	341,4	647,7	352,3	403,4	571,5	16
1130/2130G	0,719	0,925	1075	440	500	165,10	2 572	17	911,4	761,7	371,3	584,2	9,7	886,0	362,0	708,2	371,3	434,8	609,6	19
1140/2140G	0,911	1,140	920	460	535	177,80	3 062	17	965,2	805,9	393,2	635,0	9,7	939,8	378,0	749,3	393,7	457,2	660,4	19
1150/2150G	1,100	1,350	770	490	580	190,50	3 751	21	1 028,7	857,2	419,1	685,8	9,7	1 003,3	407,9	812,8	419,1	482,6	711,2	19
1160/2160G	1,310	1,640	650	525♦♦	630♦♦	254,00	4 631	22	1 111,2	908,3	441,3	736,6	12,7	1 085,8	419,1	886,0♦	441,5	501,6	762,0♦	25
1180/2180G	1,660	2,140	480	600♦♦	710♦♦	285,75	6 069	25	1 219,2	939,8	457,2	838,2	12,7	1 193,8	434,8	993,6♦	457,2	520,7	863,6♦	25
1200/2200G	2,140	2,850	370	660♦♦	780♦♦	317,50	8 482	34	1 358,9	1 098,6	536,6	927,1	12,7	1 308,1	514,4	1 095,2♦	536,4	635,0	965,2♦	25
1220/2220G	2,720	3,560	290	725♦♦	890♦♦	349,25	11 680	54	1 511,3	1 196,8	584,2	1 016,0	15,7	1 473,2	565,2	1 244,6♦	584,2	685,8	1 066,8♦	28
1240/2240G	3,470	4,480	270	810♦♦	940♦♦	381,00	14 388	57	1 632,0	1 285,7	628,6	1 130,3	15,7	1 581,2	606,6	1 314,7♦	628,6	723,9	1 168,4♦	28
1260/2260G	4,490	5,480	250	880♦♦	1 015♦♦	412,75	17 722	61	1 746,2	1 374,6	673,1	1 231,9	15,7	1 695,5	647,7	1 422,4♦	673,1	774,7	1 270,0♦	28
1280/2280G	5,840	6,760	230	950♦♦	1 090♦♦	444,50	21 110	70	1 866,9	1 412,2	691,9	1 333,5	15,7	1 803,4	666,8	1 530,6♦	691,9	793,8	1 371,6♦	28
1300/2300G	6,760	8,190	220	1 025♦♦	1 170♦♦	476,25	24 712	77	1 974,8	1 450,8	711,2	1 435,1	15,7	1 911,4	685,8	1 638,3♦	711,2	800,1	1 473,2♦	28

★ See Page 15 for General Information and other Reference Notes.

♦ Reduced shank diameter hubs are available where required bore permits. See Table 31, Page 53 for selection.

\* Dimension K may be an "as cast" surface depending upon coupling size and bore.

■ Note: There is no standardization of metric keys and keyways for bores greater than 500 mm.

Maximum bores for flex hubs 1150G and rigid hubs 1130G and larger are based on a hub diameter to bore ratio of 1.4.

# Type G52 Large Flanged Sleeve

## Floating Shaft Single Engagement/Dimensions — Millimeters

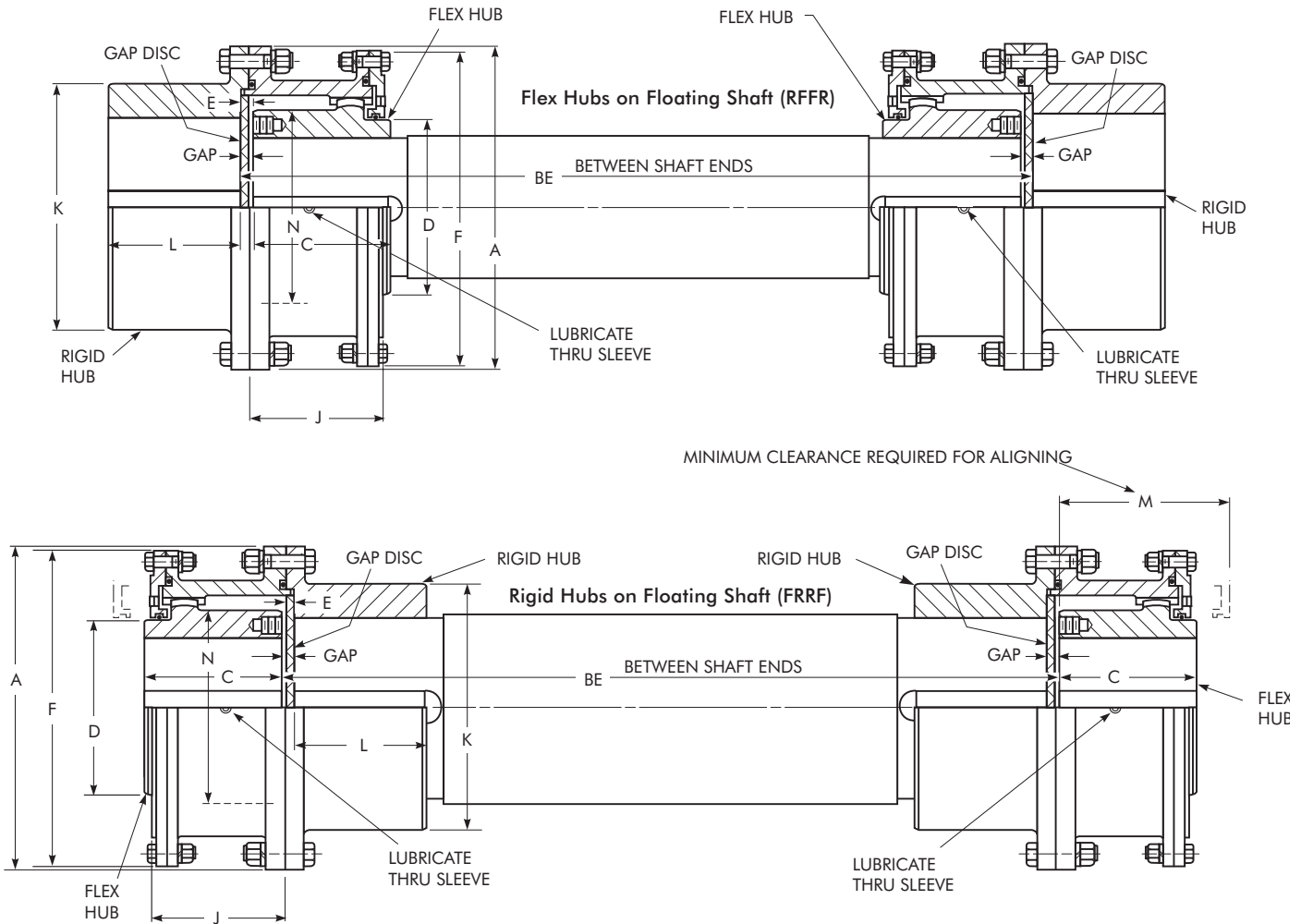

SIZE ★	Torque Rating (Nm) † (millions)		Allow Speed rpm ▲	Max Bore (mm) •		One Cplg Wt With No Bore (kg)	One Cplg Lube Wt (kg)	DIMENSIONS – Millimeters												
	1000 Series	2000 Series		Flex Hub	Rigid Hub			BE Min		C	D	E	F	J	K*	L	M	N	Gap	
								RFFR	FRRF											
1080/2080G	0,170	0,234	1300	266	340	699	5	590,6	774,7	549,1	249,4	355,6	8,1	571,5	242,8	450,8	248,9	300,0	368,3	13
1090/2090G	0,226	0,315	1160	290	380	984	6	660,4	825,5	606,6	276,4	393,7	8,1	641,4	265,2	508,0	275,8	327,2	419,1	14
1100/2100G	0,310	0,443	1090	320	400	1 252	8	711,2	927,1	666,8	304,8	444,5	9,7	698,5	293,6	530,4	304,8	355,6	469,9	16
1110/2110G	0,413	0,609	1000	373	440	1 637	9	774,7	1 028,7	723,9	333,2	495,3	9,7	749,3	322,3	584,2	333,2	384,0	520,7	16
1120/2120G	0,555	0,777	900	400	483	2 077	11	838,2	1 104,9	762,0	352,6	546,1	9,7	825,5	341,4	647,7	352,3	403,4	571,5	16
1130/2130G	0,719	0,925	800	440	500 ♣	2 572	17	911,4	1 130,3	806,4	371,3	584,2	9,7	886,0	362,0	708,2	371,3	434,8	609,6	19
1140/2140G	0,911	1,140	700	460	535 ♣	3 062	17	965,2	1 181,1	850,9	393,2	635,0	9,7	939,8	378,0	749,3	393,7	457,2	660,4	19
1150/2150G	1,100	1,350	580	490	580 ♣	3 751	21	1 028,7	1 295,4	901,7	419,1	685,8	9,7	1 003,3	407,9	812,8	419,1	482,6	711,2	19
1160/2160G	1,310	1,640	490	525 ♣♣	630 ♣♣	4 631	22	1 111,2	1 320,8	958,8	441,3	736,6	12,7	1 085,7	419,1	886,0 ♣	441,5	501,7	762,0 ♣	25
1180/2180G	1,660	2,140	360	600 ♣♣	710 ♣♣	6 069	25	1 219,2	1 358,9	990,6	457,2	838,2	12,7	1 193,8	434,8	993,6 ♣	457,2	520,7	863,6 ♣	25
1200/2200G	2,140	2,850	280	660 ♣♣	780 ♣♣	8 482	34	1 358,9	1 451,0	1 149,4	536,6	927,1	12,7	1 308,1	514,4	1 095,2 ♣	536,4	635,0	965,2 ♣	25
1220/2220G	2,720	3,560	220	725 ♣♣	890 ♣♣	11 680	54	1 511,3	1 828,8	1 251,0	584,2	1 016,0	15,7	1 473,2	565,2	1 244,6 ♣	584,2	685,8	1 066,8 ♣	28
1240/2240G	3,470	4,480	200	810 ♣♣	940 ♣♣	14 388	57	1 632,0	1 993,9	1 339,8	628,6	1 130,3	15,7	1 581,2	606,6	1 314,7 ♣	628,6	723,9	1 168,4 ♣	28
1260/2260G	4,490	5,480	190	880 ♣♣	1 015 ♣♣	17 722	61	1 746,2	2 159,0	1 428,8	673,1	1 231,9	15,7	1 695,4	647,7	1 422,4 ♣	673,1	774,7	1 270,0 ♣	28
1280/2280G	5,840	6,760	175	950 ♣♣	1 090 ♣♣	21 110	70	1 866,9	2 222,5	1 454,2	691,9	1 333,5	15,7	1 803,4	666,8	1 530,6 ♣	691,9	793,8	1 371,6 ♣	28
1300/2300G	6,760	8,190	165	1 025 ♣♣	1 170 ♣♣	24 712	77	1 974,8	2 286,0	1 505,0	711,2	1 435,1	15,7	1 911,4	685,8	1 638,3 ♣	711,2	800,1	1 473,2 ♣	28

★ See Page 15 for General Information and other Reference Notes.

♣ Reduced shank diameter hubs are available when required bore permits. See Table 31, Page 53 for selection.

\* Dimension K may be as "as cast" surface depending upon coupling size and bore.

▲ The allowable speed for floating shaft assemblies is the smaller value of either the critical speed of the selected shaft or the cataloged speed of the selected size coupling. The allowable operating speed should be based on torque, misalignment, balance, and other operating requirements for the specific application. If higher speeds are required or special application requirements must be met, consult the Factory for assistance.

♣ See Page 43 for footnote.

# Type GV20 Large Flanged Sleeve

## Vertical Double Engagement/Dimensions — Millimeters

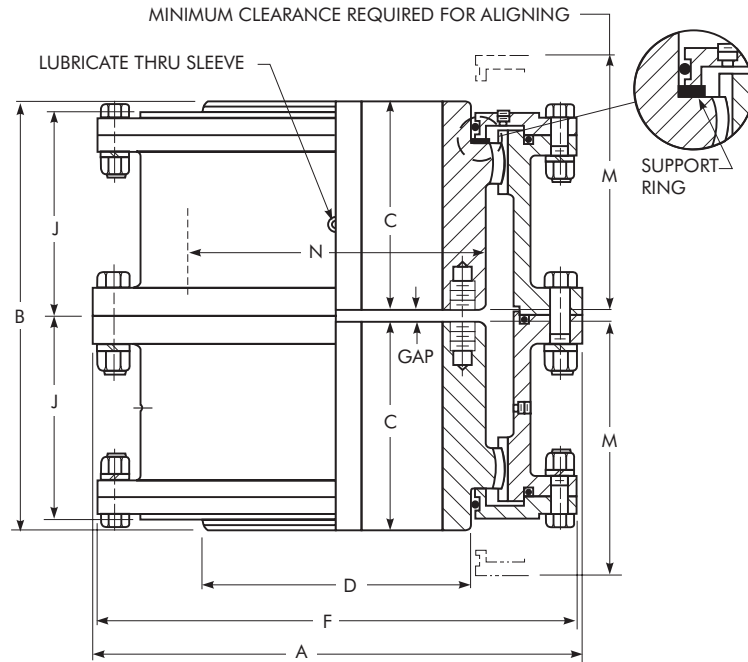

SIZE ★	Torque Rating (Nm) †		Allow Speed rpm	Max Bore (mm) •	Min Bore (mm) ■	Cplg Wt With No Bore (kg)	Lube Wt (kg)	DIMENSIONS — Millimeters								
	1000 Series	2000 Series						A	B	C	D	F	J	M	N	Gap
1080/2080GV	0,170	0,234	1750	266	101,60	703	13	590,6	508,5	249,4	355,6	571,5	242,8	300,0	368,3	10
1090/2090GV	0,226	0,315	1550	290	114,30	984	17	660,4	565,4	276,4	393,7	641,4	265,2	327,2	419,1	13
1100/2100GV	0,310	0,443	1450	320	127,00	1 302	21	711,2	622,3	304,8	444,5	698,5	293,6	355,6	469,9	13
1110/2110GV	0,413	0,609	1330	373	139,70	1 678	24	774,7	679,2	333,2	495,3	749,3	322,3	384,0	520,7	13
1120/2120GV	0,555	0,777	1200	400	152,40	2 114	30	838,2	717,8	352,6	546,1	825,5	341,4	403,4	571,5	13
1130/2130GV	0,719	0,925	1075	440	165,10	2 595	44	911,4	761,7	371,3	584,2	886,0	362,0	434,8	609,6	19
1140/2140GV	0,911	1,140	920	460	177,80	3 107	49	965,2	805,4	393,7	635,0	939,8	378,0	457,2	660,4	19
1150/2150GV	1,100	1,350	770	490	190,50	3 765	59	1 028,7	857,3	419,1	685,8	1 003,3	407,9	482,6	711,2	19
1160/2160GV	1,310	1,640	650	525◆♣	254,00	4 708	141	1 111,2	908,1	441,3	736,6	1 085,8	419,1	501,6	762,0◆	25
1180/2180GV	1,660	2,140	480	600◆♣	285,75	6 260	168	1 219,2	939,8	457,2	838,2	1 193,8	434,8	520,7	863,6◆	25
1200/2200GV	2,140	2,850	370	660◆♣	317,50	8 582	227	1 358,9	1 098,6	536,4	927,1	1 308,1	514,4	635,0	965,2◆	25
1220/2220GV	2,720	3,560	290	725◆♣	349,25	11 685	319	1 511,3	1 193,8	584,2	1 016,0	1 473,2	565,2	685,8	1 066,8◆	25
1240/2240GV	3,470	4,480	270	810◆♣	381,00	14 606	341	1 632,0	1 282,7	628,6	1 130,3	1 581,2	606,6	723,9	1 168,4◆	25
1260/2260GV	4,490	5,480	250	880◆♣	412,75	17 799	402	1 746,2	1 371,6	673,1	1 231,9	1 695,4	647,7	774,7	1 270,0◆	25
1280/2280GV	5,840	6,760	230	950◆♣	444,50	21 192	450	1 866,9	1 409,2	691,9	1 333,5	1 803,4	666,8	793,8	1 371,6◆	25
1300/2300GV	6,760	8,190	220	1 025◆♣	476,25	24 807	499	1 974,8	1 447,8	711,2	1 435,1	1 911,4	685,8	800,1	1 473,2◆	25

★ See Page 15 for General Information and other Reference Notes.

◆ Reduced shank diameter hubs are available where bore permits. See Table 31, Page 53, for selections.

♣ Note: There is no standardization of metric keys and keyways for bores greater than 500 mm.

Maximum bores for flex hubs 1150G and larger are based on a hub diameter to bore ratio of 1.4.

# Type GV52 Large Flanged Sleeve

## Vertical Single Engagement/Dimensions — Millimeters

**IMPORTANT** — When couplings are mounted on a floating shaft, do not exceed allowable shaft speed for the assembly,

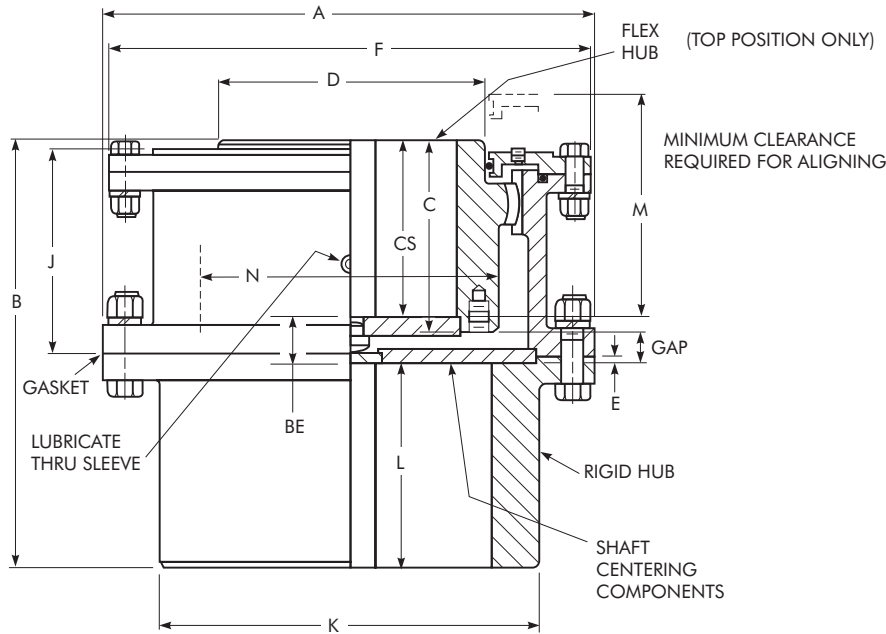

SIZE ★	Torque Rating (Nm) †		Allow Speed rpm	Max Bore (mm) *		Min Bore Both Hubs (mm) †	Cplg Wt. With No Bore (kg)	Lube Wt (kg)	DIMENSIONS — Millimeters													
	1000 Series	2000 Series		Flex Hub	Rigid Hub				A	B	C	D	E	F	J	K*	L	M	N	BE	CS	Gap
	1080/2080G	0,170		0,234	1750				266	340	101,60	699	4,99	590,6	511,6	236,7	355,6	8,1	571,5	242,8	450,8	248,9
1090/2090G	0,226	0,315	1550	290	380	114,30	984	6,35	660,4	567,2	261,9	393,7	8,1	641,4	265,2	508,0	275,8	314,5	419,1	42,2	249,2	29
1100/2100G	0,310	0,443	1450	320	400	127,00	1252	7,71	711,2	625,3	288,8	444,5	9,7	698,5	293,6	530,4	304,8	339,9	469,9	48,3	273,1	33
1110/2110G	0,413	0,609	1330	373	440	139,70	1637	9,07	774,7	682,8	317,2	495,3	9,7	749,3	322,3	584,2	333,2	368,3	520,7	48,3	301,5	33
1120/2120G	0,555	0,777	1200	400	483	152,40	2077	10,9	838,2	721,4	336,6	546,1	9,7	825,5	341,4	647,7	352,3	387,4	571,5	48,3	320,8	33
1130/2130G	0,719	0,925	1075	440	500	165,10	2572	16,8	911,4	762,0	352,0	584,2	9,7	886,0	362,0	708,2	371,3	419,1	609,6	54,9	336,3	39
1140/2140G	0,911	1,140	920	460	535	177,80	3062	17,2	965,2	806,4	373,9	635,0	9,7	939,8	378,0	749,3	393,7	441,5	660,4	54,9	358,1	39
1150/2150G	1,100	1,350	770	490	580	190,50	3751	20,9	1 028,7	857,2	399,8	685,8	9,7	1 003,3	407,9	812,8	419,1	466,9	711,2	54,9	384,0	39
1160/2160G	1,310	1,640	650	525♦♣	630♦♣	254,00	4631	21,8	1 111,2	908,0	416,1	736,6	12,7	1 085,8	419,1	886,0♦	441,5	482,6	762,0♦	70,4	397,0	51
1180/2180G	1,660	2,140	480	600♦♣	710♦♣	285,75	6069	25,4	1 219,2	939,8	431,8	838,2	12,7	1 193,8	434,8	993,6♦	457,2	501,6	863,6♦	70,4	412,8	51
1200/2200G	2,140	2,850	370	660♦♣	780♦♣	317,50	8482	34,5	1 358,9	1 098,6	511,0	927,1	12,7	1 308,1	514,4	1 095,2♦	536,4	616,0	965,2♦	70,4	492,3	51
1220/2220G	2,720	3,560	290	725♦♣	890♦♣	349,25	11 680	54,4	1 511,3	1 196,8	555,8	1 016,0	15,7	1 473,2	565,2	1 244,6♦	584,2	660,4	1 066,8♦	83,3	530,4	58
1240/2240G	3,470	4,480	270	810♦♣	940♦♣	381,00	14 388	56,7	1 632,0	1 285,7	599,9	1 130,3	15,7	1 581,2	606,6	1 314,7♦	628,6	698,5	1 168,4♦	83,3	574,5	58
1260/2260G	4,490	5,480	250	880♦♣	1 015♦♣	412,75	17 722	61,2	1 746,2	1 374,6	644,7	1 231,9	15,7	1 695,4	647,7	1 422,4♦	673,1	749,3	1 270,0♦	83,1	619,3	58
1280/2280G	5,840	6,760	230	950♦♣	1 090♦♣	444,50	21 110	70,3	1 866,9	1 412,7	663,4	1 333,5	15,7	1 803,4	666,8	1 530,6♦	691,9	768,4	1 371,6♦	83,1	638,0	58
1300/2300G	6,760	8,190	220	1 025♦♣	1 170♦♣	476,25	24 712	77,1	1 974,8	1 450,8	682,8	1 435,1	15,7	1 911,4	685,8	1 638,3♦	711,2	774,7	1 473,2♦	83,1	657,4	58

★ See Page 15 for General Information and other Reference Notes. Downward load capacity of lower coupling supporting button for Size 1080GV52 and larger is 39 463 kilograms.

♦ Reduced shank diameter hubs are available where required bore permits. See Table 31, Page 53 for selections.

\* Dimension K may be an "as cast" surface depending upon coupling size and bore.

♣ Note: There is no standardization of metric keys and keyways for bores greater than 500 mm.

Maximum bores for flex hubs 1150G and rigid hubs 1130G and larger are based on a hub diameter to bore ratio of 1.4.

# Type GL20-4 Large Flanged Sleeve

## Slide Double Engagement/Dimensions — Millimeters

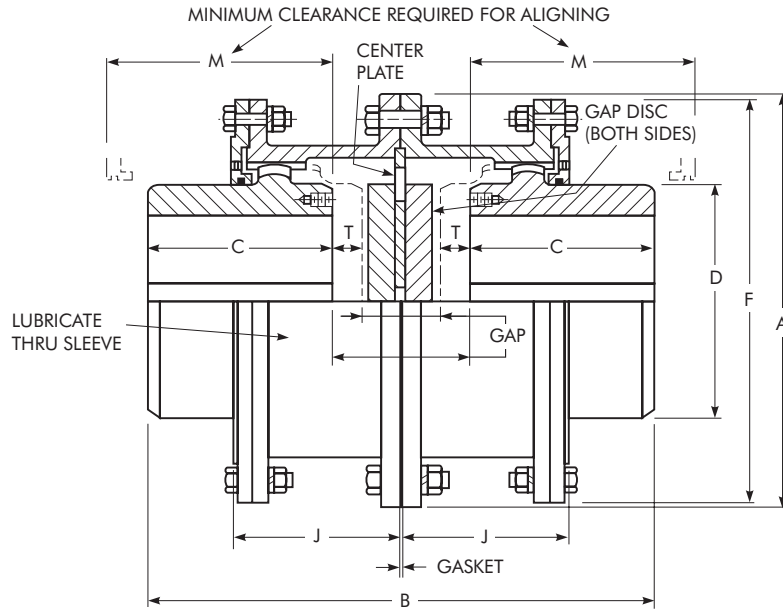

SIZE ★	Torque Rating (Nm) † (millions)		Allow Speed rpm †	Max Bore (mm) •	Min Bore (mm) ■	Cplg Wt With No Bore (kg)	Lube Wt (kg)	DIMENSIONS — Millimeters										
	1000 Series	2000 Series						A	B Max	C	D	F	J	M	T (Max)		Gap	
															Each	Total	Min	Max
1080/2080GL	0,170	0,234	1160	266	101,60	685	9,53	590,6	740,2	249,4	355,6	571,5	242,8	300,0	14,0	27,9	213	241
1090/2090GL	0,226	0,315	1030	290	114,30	943	12,2	660,4	793,0	276,4	393,7	641,4	265,2	327,2	22,9	45,7	195	240
1100/2100GL	0,310	0,443	960	320	127,00	1 247	15,0	711,2	893,6	304,8	444,5	698,5	293,6	355,6	21,1	42,2	242	284
1110/2110GL	0,413	0,609	880	373	139,70	1 610	17,7	774,7	994,2	333,2	495,3	749,3	322,3	384,0	19,0	38,1	290	328
1120/2120GL	0,555	0,777	800	400	152,40	2 037	20,9	838,2	1 061,2	352,6	546,1	825,5	341,4	403,4	19,0	38,1	318	356

★ See Page 15 for General Information and Reference Notes.

# Type G70

## Disconnect/Dimensions — Millimeters

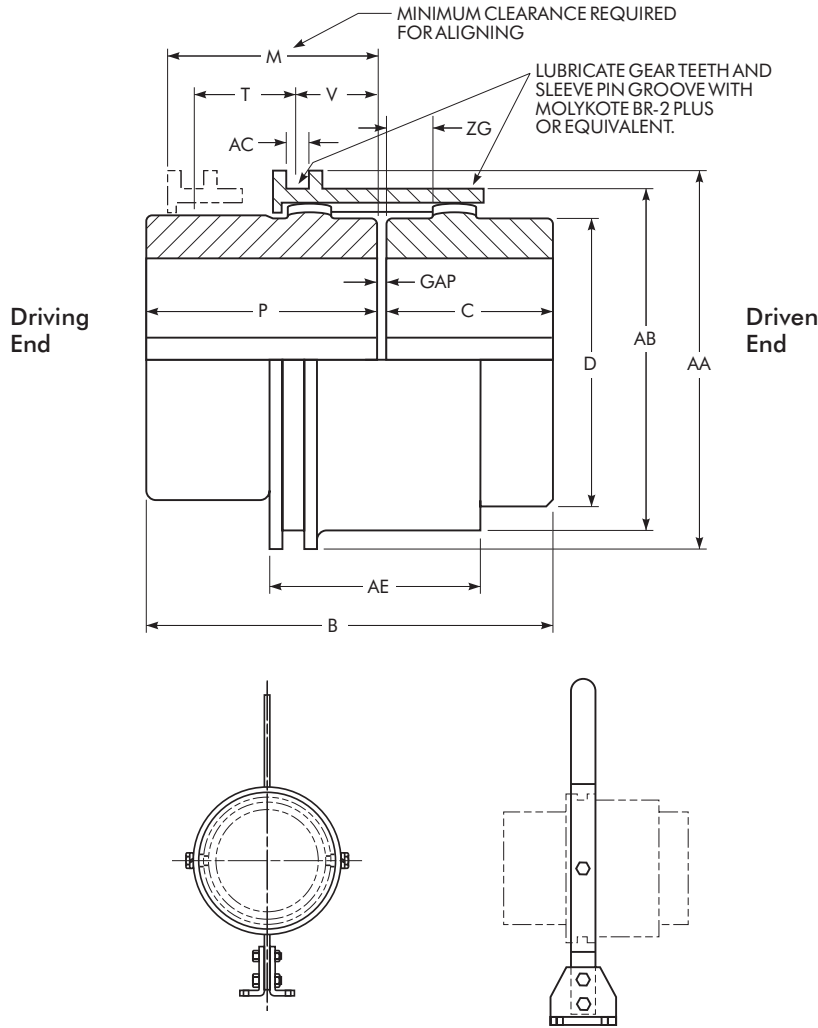

Optional hand operated shifter mechanism to shift and secure the proper position of the sleeve assembly.

SIZE ★	Torque Rating (Nm) (millions) †	Allow Speed rpm ‡	Max Bore (mm) •	Min Bore (mm) ▫	Cplg Wt With No Bore (kg)	DIMENSIONS — Millimeters												
						B	C	D	M	P	T	V	AA	AB	AC	AE	ZG	Gap
1080G	0,170	110	266	101,60	498	508,0	249,4	368,3	228,6	249,4	108,2	88,4	491,7	461,3	19,3	215,9	41,4	10
1090G	0,226	100	290	114,30	698	559,3	276,4	419,1	263,7	270,3	130,6	95,0	556,3	515,6	25,4	251,0	52,8	13
1100G	0,310	90	320	127,00	956	622,3	304,8	469,9	283,0	304,8	137,2	107,7	607,1	566,4	25,4	270,3	52,8	13
1110G	0,413	80	373	139,70	1 256	679,2	333,2	520,7	296,2	333,2	143,8	114,3	655,3	614,7	25,4	283,5	52,8	13
1120G	0,555	75	400	152,40	1 559	702,6	352,6	571,5	292,1	337,3	149,4	104,6	711,2	670,6	25,4	279,4	52,3	13
1130G	0,719	70	440	165,10	1 779	697,0	338,8	609,6	288,5	338,8	141,7	102,6	778,3	727,5	31,5	275,8	32,0	19
1140G	0,911	65	460	177,80	2 127	719,3	350,0	660,4	288,5	350,0	141,7	102,6	828,0	777,2	31,5	275,8	26,9	19
1150G	1,100	60	490	190,50	2 623	770,1	375,4	711,2	288,5	375,4	141,7	102,6	882,4	831,6	31,5	275,8	21,3	19

★ See Page 15 for General Information and Reference Notes.



# Type G82 Large Flanged Sleeve

## Rigid/Dimensions — Millimeters

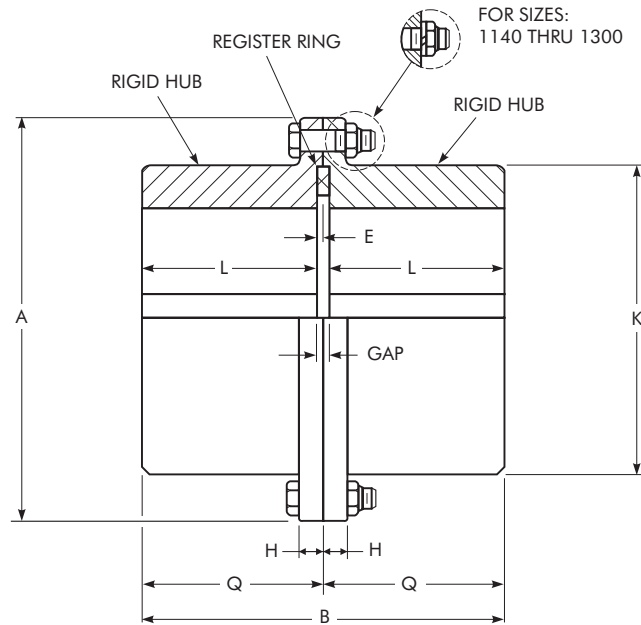

SIZE ★	Torque Rating (Nm) (millions) †	Allow Speed rpm ‡	Max Bore (mm) •	Min Bore (mm) ■	Cplg Wt With No Bore (kg)	DIMENSIONS — Millimeters							
						A	B	E	H	K *	L	Q	Gap
<b>1080G</b>	0,170	1750	340	101,60	699	590,6	514,1	8,1	31,5	450,8	248,9	257,0	16
<b>1090G</b>	0,226	1550	380	114,30	984	660,4	567,9	8,1	38,1	508,0	275,8	284,0	16
<b>1100G</b>	0,310	1450	400	127,00	1207	711,2	628,9	9,7	44,2	530,4	304,8	314,5	19
<b>1110G</b>	0,413	1330	440	139,70	1601	774,7	685,8	9,7	50,8	584,2	333,2	342,9	19
<b>1120G</b>	0,555	1200	483	152,40	2050	838,2	723,9	9,7	53,8	647,7	352,3	362,0	19
<b>1130G</b>	0,719	1075	500†	165,10	2558	911,4	762,0	9,7	53,8	708,2	371,3	381,0	19
<b>1140G</b>	0,911	920	535†	177,80	3030	965,2	806,7	9,7	53,8	749,3	393,7	403,4	19
<b>1150G</b>	1,100	770	580†	190,50	3747	1 028,7	857,5	9,7	53,8	812,8	419,1	428,8	19
<b>1160G</b>	1,310	650	630◆♣	254,00	4681	1 111,2	908,3	12,7	57,2	886,0◆	441,5	454,2	25
<b>1180G</b>	1,660	480	710◆♣	285,75	6024	1 219,2	939,8	12,7	57,2	993,6◆	457,2	469,9	25
<b>1200G</b>	2,140	370	780◆♣	317,50	8573	1 358,9	1 098,3	12,7	63,5	1 095,2◆	536,4	549,1	25
<b>1220G</b>	2,720	290	890◆♣	349,25	11 893	1 511,3	1 199,9	15,7	63,5	1 244,6◆	584,2	599,9	31
<b>1240G</b>	3,470	270	940◆♣	381,00	14 524	1 632,0	1 289,3	15,7	76,2	1 314,7◆	628,9	644,7	31
<b>1260G</b>	4,490	250	1 015◆♣	412,75	18 035	1 746,2	1 377,7	15,7	76,2	1 422,4◆	673,1	688,8	31
<b>1280G</b>	5,840	230	1 090◆♣	444,50	21 473	1 866,9	1 415,3	15,7	82,3	1 530,6◆	691,9	707,6	31
<b>1300G</b>	6,760	220	1 170◆♣	476,25	25 124	1 974,8	1 453,9	15,7	82,3	1 638,3◆	711,2	726,9	31

★ See Page 15 for General Information and other Reference Notes.

◆ Dimension K may be an "as-cast" surface depending upon coupling size and bore.

\* For standard shank diameter hubs.

♣ **Note:** There is no standardization of metric keys and keyways for bores greater than 500 mm.

Maximum bores for rigid hubs 1130G and larger are based on a hub diameter to bore ratio of 1.4.

# Type GR20 Large Flanged Sleeve

## Shear Pin Double Engagement/Dimensions — Millimeters

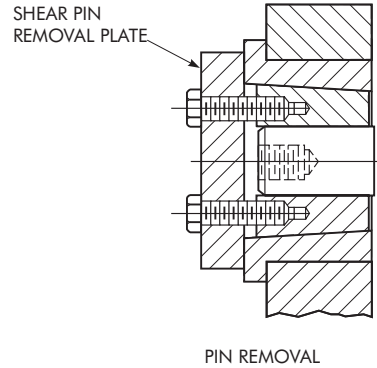
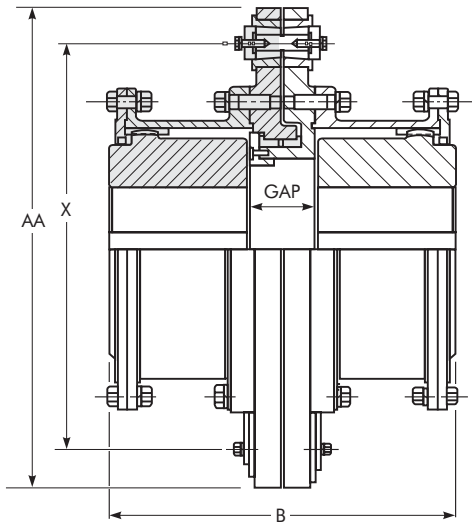

SIZE ★	1000 Series		2000 Series		Allow Speed rpm †	Max Bore (mm) •	Min Bore (mm) =	Approximate Value — Millimeters			
	Shear Torque (Nm x 10 <sup>6</sup> )		Shear Torque (Nm x 10 <sup>6</sup> )					AA	X	Gap	B
	Min	Max	Min	Max							
1080/2080GR	0,052	0,235	0,081	0,366	880	266	101,6	990,6	812,8	121	619,8
1090/2090GR	0,071	0,319	0,107	0,495	780	290	114,3	1 066,8	889,0	127	679,7
1100/2100GR	0,099	0,449	0,156	0,696	730	320	127,0	1 117,6	939,8	146	755,9
1110/2110GR	0,137	0,617	0,215	0,960	670	373	139,7	1 168,4	990,6	165	831,6
1120/2120GR	0,176	0,795	0,271	1,22	600	400	152,4	1 244,6	1 066,8	178	882,9
1130/2130GR	0,216	0,983	0,327	1,47	540	440	165,1	1 346,2	1 143,0	184	927,1
1140/2140GR	0,258	1,16	0,403	1,82	460	460	177,8	1 409,7	1 193,8	197	984,5
1150/2150GR	0,299	1,34	0,460	2,07	390	490	190,5	1 485,9	1 257,3	203	1 041,4
1160/2160GR	0,384	1,71	0,571	2,57	330	525 ♣	254,0	1 600,2	1 346,2	229	1 111,5
1180/2180GR	0,498	2,23	0,747	3,35	240	600 ♣	285,8	1 651,0	1 447,8	241	1 155,7
1200/2200GR	0,647	3,02	1,00	4,47	190	660 ♣	317,5	1 803,4	1 600,2	261	1 333,5
1220/2220GR	0,847	3,80	1,25	5,59	150	725 ♣	349,2	1 930,4	1 727,2	273	1 441,7
1240/2240GR	1,05	4,69	1,57	7,04	140	810 ♣	381,0	2 057,4	1 854,2	305	1 562,1
1260/2260GR	1,29	5,81	1,92	8,60	130	880 ♣	412,8	2 184,4	1 981,2	324	1 670,3
1280/2280GR	1,54	6,93	2,37	10,62	120	950 ♣	444,5	2 311,4	2 108,2	337	1 721,1
1300/2300GR	1,87	8,38	2,87	12,85	110	1 025 ♣	476,2	2 413,0	2 209,8	362	1 784,6

★ See Page 15 for General Information and Reference Notes.

♣ Note: There is no standardization of metric keys and keyways for bores greater than 500 mm.  
Maximum bores for flex hubs 1150G and larger are based on a hub diameter to bore ratio of 1.4.

# Engineering Data — Large Flanged Sleeve

**TABLE 24 — Recommended Commercial Keys for Bores with One Key — Millimeters (Per ISO R773 Standard)**

Shaft Diameter		Key Size
Over	Thru	
95	110	28 x 16
110	130	32 x 18
130	150	36 x 20
150	170	40 x 22
170	200	45 x 25
200	230	50 x 28
230	260	56 x 32
260	290	63 x 32
290	330	70 x 36
330	380	80 x 40
380	440	90 x 45
440	500	100 x 50

★ **Note:** For metric recommended keys of shafts above 500 mm, consult the Factory.

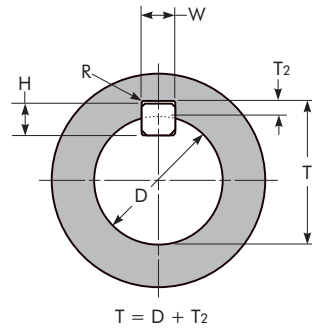

Check Key Stresses

**TABLE 25 — Recommended Bore Tolerances Rexnord Steel Coupling Hubs – Millimeters**

Shaft Diameter (ISO/R775-1969)		Bore Diameter Tolerance		
Nominal	Tolerance	Clearance	Transitional	Interference
6 to 30	i6/k6 ♦	F7	H7	M6
Over 30 to 50	k6	F7	H7	K6
Over 50 to 80	m6	F7	H7	K7
Over 80 to 100	m6	F7	H7	M7
Over 100 to 200	m6	F7	H7	P7
Over 200 to 355	m6	F7	H7	R7
Over 355 to 500	m6	F7	H7	R8

♦ Per DIN 748 — Differs with ISO/R775.

# Engineering Data — Large Flanged Sleeve

**TABLE 26 — Flange Details — Millimeters**

SIZE	A	B	C	E	DD	F	G	H	J Bolts No. Dia x Lgth (Per Flange) (Inch)	K Bolts No. Dia x Lgth (Inch)	T
1080/2080G	590,6	527,05	441,33	7,9	6,4	571,5	527,05	31,8	16- .875 x 3.25	16- 1.125 x 4.125	441,27
1090/2090G	660,4	590,55	495,30	7,9	6,4	641,4	590,55	38,1	18- 1.000 x 3.50	18- 1.250 x 4.75	495,25
1100/2100G	711,2	641,35	546,10	9,7	7,9	698,5	641,35	44,4	18- 1.000 x 3.50	18- 1.250 x 5.25	546,05
1110/2110G	774,7	698,50	596,90	9,7	7,9	749,3	698,50	50,8	18- 1.000 x 3.50	18- 1.500 x 6.00	596,85
1120/2120G	838,2	762,00	654,05	9,7	7,9	825,5	762,00	53,8	18- 1.125 x 3.50	18- 1.500 x 6.25	654,00
1130/2130G	911,4	822,33	708,03	9,7	7,9	886,0	822,33	53,8	18- 1.250 x 4.50	18- 1.500 x 6.25	707,97
1140/2140G	965,2	876,30	758,83	9,7	7,9	939,8	876,30	53,8	18- 1.250 x 4.50	18- 1.750 x 6.50	758,77
1150/2150G	1 028,7	933,45	815,98	9,7	7,9	1 003,3	933,45	53,8	20- 1.250 x 4.50	20- 1.750 x 6.50	815,92
1160/2160G	1 111,2	1 009,65	863,60	12,7	9,7	1 085,9	1 009,65	57,2	20- 1.250 x 4.50	20- 2.000 x 7.00	863,50
1180/2180G	1 219,2	1 117,60	984,25	12,7	9,7	1 193,8	1 117,60	57,2	22- 1.250 x 5.00	22- 2.000 x 7.00	984,15
1200/2200G	1 358,9	1 231,90	1 085,85	12,7	9,7	1 308,1	1 231,90	63,5	22- 1.500 x 5.00	22- 2.250 x 7.75	1 085,75
1220/2220G	1 511,3	1 384,30	1 212,85	15,7	12,7	1 473,2	1 384,30	63,5	24- 1.500 x 5.00	24- 2.250 x 7.75	1 212,75
1240/2240G	1 632,0	1 479,55	1 289,05	15,7	12,7	1 581,2	1 479,55	76,2	22- 1.500 x 5.00	22- 2.750 x 9.75	1 288,95
1260/2260G	1 746,2	1 593,85	1 390,65	15,7	12,7	1 695,5	1 593,85	76,2	24- 1.500 x 5.00	24- 2.750 x 9.75	1 390,55
1280/2280G	1 866,9	1 701,80	1 492,25	15,7	12,7	1 803,4	1 701,80	82,6	22- 1.500 x 5.00	22- 3.000 x 10.50	1 492,15
1300/2300G	1 974,8	1 809,75	1 593,85	15,7	12,7	1 911,4	1 809,75	82,6	24- 1.500 x 5.00	24- 3.000 x 10.50	1 593,75

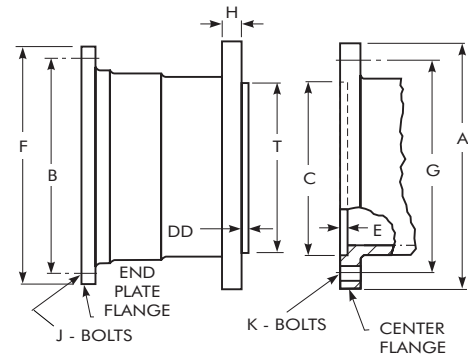

**TABLE 27 — Sleeve Jack Screw Holes**

SIZE	B.C. (mm)	Tap Size (in)
1080/2080G	527,0	.875-9 UNC
1090/2090G	590,6	1.000-8 UNC
1100/2100G	641,4	1.000-8 UNC
1110/2110G	698,5	1.000-8 UNC
1120/2120G	762,0	1.125-7 UNC
1130/2130G	822,3	1.250-7 UNC
1140/2140G	876,3	1.250-7 UNC
1150/2150G	933,4	1.250-7 UNC
1160/2160G	1 009,6	1.250-7 UNC
1180/2180G	1 117,6	1.250-7 UNC
1200/2200G	1 231,9	1.500-6 UNC
1220/2220G	1 384,3	1.500-6 UNC
1240/2240G	1 479,6	1.500-6 UNC
1260/2260G	1 593,8	1.500-6 UNC
1280/2280G	1 701,8	1.500-6 UNC
1300/2300G	1 809,8	1.500-6 UNC

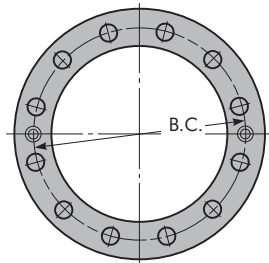

**TABLE 28 — Flex Hub Puller Bolt Holes for Standard Shank Diameter Hubs**

SIZE *	B.C. (mm)	Tap Size – UNC (in)
1080/2080G	317,5	1.000-8 x 1.18
1090/2090G	355,6	1.250-7 x 1.50
1100/2100G	393,7	1.500-6 x 1.75
1110/2110G	444,5	1.500-6 x 1.75
1120/2120G	495,3	1.500-6 x 1.75
1130/2130G	533,4	1.500-6 x 1.75
1140/2140G	584,2	1.500-6 x 1.75
1150/2150G	635,0	1.500-6 x 1.75
1160/2160G	685,8	1.500-6 x 1.75
1180/2180G	774,7	1.500-6 x 1.75
1200/2200G	863,6	2.000-4.5 x 2.38
1220/2220G	952,5	2.000-4.5 x 2.38
1240/2240G	1 041,4	2.000-4.5 x 2.38
1260/2260G	1 143,0	2.000-4.5 x 2.38
1280/2280G	1 244,6	2.000-4.5 x 2.38
1300/2300G	1 346,2	2.000-4.5 x 2.38

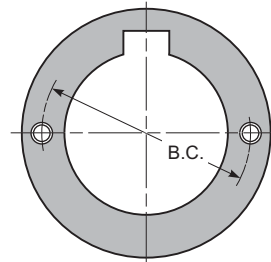

\* Refer to Table 32 for flex hub puller data on reduced shank diameter hubs, Sizes 1160/2160 thru 1300/2300.

**TABLE 29 — Torsional Stiffness – Nm/Radian (10<sup>6</sup>)**

SIZE	Half Coupling				Complete Coupling			
	Flex Half	Rigid Half			Type G20	Type G52		
		Large Shank	Medium Shank	Small Shank		Large Shank	Medium Shank	Small Shank
1080/2080G	510,7	1 412,4	...	...	255,4	375,1	...	...
1090/2090G	696,0	2 056,4	...	...	348,0	519,8	...	...
1100/2100G	881,3	2 248,5	...	...	440,7	632,7	...	...
1110/2110G	1 068,9	3 028,1	...	...	534,4	790,9	...	...
1120/2120G	1 423,7	4 304,9	...	...	711,8	1 070,0	...	...
1130/2130G	1 794,3	5 785,1	...	...	897,1	1 367,2	...	...
1140/2140G	2 119,7	6 835,9	...	...	1 059,9	1 615,8	...	...
1150/2150G	2 508,2	8 802,0	...	...	1 254,2	1 954,7	...	...
1160/2160G	3 457,5	12 078,7	7 412,2	2 994,2	1 728,8	2 689,2	2 361,5	1 604,5
1180/2180G	5 265,4	18 315,8	10 937,5	4 700,4	2 632,7	4 101,6	3 559,2	2 485,8
1200/2200G	5 988,5	23 004,9	13 705,8	6 022,4	2 994,2	4 745,6	4 158,1	3 005,5
1220/2220G	10 824,5	34 857,6	17 875,1	8 146,6	5 412,2	8 259,6	6 745,5	4 643,9
1240/2240G	10 508,1	40 789,6	23 106,6	10 496,8	5 254,1	8 350,0	7 220,1	5 254,1
1260/2260G	13 197,3	51 862,6	28 993,4	13 581,5	6 598,6	10 519,4	9 073,1	6 700,3
1280/2280G	17 377,9	67 737,8	37 422,5	18 055,9	8 689,0	13 830,0	11 864,0	8 858,5
1300/2300G	22 146,1	86 155,3	47 139,6	23 264,7	11 073,1	17 615,2	15 072,9	11 344,2

**TABLE 30 — WR<sup>2</sup> Values – KgM<sup>2</sup>**

WR<sup>2</sup> values are based on hubs with no bore.

SIZE	Type G20 Double Engagement	Type G52 Single Engagement
1080/2080G	22,2	21,2
1090/2090G	39,9	38,0
1100/2100G	61,7	55,5
1110/2110G	93,3	86,5
1120/2120G	138	130
1130/2130G	198	189
1140/2140G	269	256
1150/2150G	365	351
1160/2160G	526	514
1180/2180G	850	829
1200/2200G	1 455	1 425
1220/2220G	2 475	2 413
1240/2240G	3 565	3 492
1260/2260G	4 887	4 883
1280/2280G	6 636	6 694
1300/2300G	8 742	8 807

# Engineering Data — Large Flanged Sleeve

## Data for couplings with reduced shank diameter hubs.

Depending upon bore, a reduced shank diameter hub (Dimension “N” or “K”) is available for each coupling, sizes 1160/2160 thru 1300/2300. This provides reduced weight and WR<sup>2</sup>.

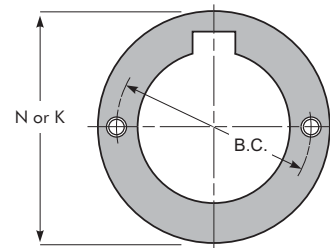

**TABLE 31 — Bore Ranges for Reduced Shank Diameter Hubs — Millimeters \***

SIZE ★	Flex Hub		Weight (kg)				Rigid Hub		K †	Weight (kg) *			Coupling WR <sup>2</sup> (Kgm <sup>2</sup> )
	Max Bore • ▲	Min Bore	N †	Sleeves End Rings and Fasteners	Flex Hub With No Bore (Each)	Coupling WR <sup>2</sup> (Kgm <sup>2</sup> )	Max Bore • ▲	Min Bore		Sleeve End Ring and Fasteners	Flex Hub With No Bore (Each)	Rigid Hub With No Bore (Each)	
<b>1160/2160G</b>	463	330	647,7	1388	1388	470	562	375	787,4	748	1388	1901	418
	376	254	527,0	1388	1193	437	426	254	596,9	...	1193	1383	338
<b>1180/2180G</b>	535	381	749,3	1642	1878	767	626	419	876,3	885	1878	2413	671
	435	286	609,6	1642	1601	702	481	286	673,1	...	1601	1787	543
<b>1200/2200G</b>	608	432	850,9	2200	2749	1315	689	470	965,2	1184	2749	3434	1152
	494	318	692,2	2200	2291	1169	535	318	749,3	...	2291	2549	922
<b>1220/2220G</b>	680	489	952,5	3257	3706	2275	753	515	1054,1	1724	3706	4468	1910
	558	349	781,0	3257	3093	2033	590	350	825,5	...	3093	3361	1545
<b>1240/2240G</b>	753	540	1054,1	3633	4826	3252	816	565	1143,0	1978	4826	5693	2808
	617	381	863,6	3633	3978	2848	644	381	901,7	...	3978	4264	2234
<b>1260/2260G</b>	826	591	1155,7	3978	6142	4454	880	610	1231,9	2164	6142	7013	3890
	676	413	946,2	3978	5008	4588	699	413	977,9	...	5008	5298	3038
<b>1280/2280G</b>	898	650	1257,3	4627	7412	6081	943	660	1320,8	2517	7412	8319	5288
	739	445	1035,0	4627	6055	5147	753	445	1054,1	...	6055	6382	4142
<b>1300/2300G</b>	971	700	1358,9	5185	8845	8035	1007	705	1409,7	2817	8845	9671	6961
	798	476	1117,6	5185	7199	6742	807	476	1130,3	...	7199	7466	5435

★ See Page 15 for General Information and other reference notes.

† Hubs with the least possible “K” or “N” dimensions for the required bore are normally furnished.

\* Total weight of coupling varies with “K” or “N” dimensions of rigid and flex hub selection. Add weight of selected hubs to “Sleeve, End Ring and Fasteners” weight.

▲ Note: Maximum bore dimensions are based upon a N/1.4 or K/1.4 ratio. For key and keyway dimensions, consult the Factory.

**TABLE 32 — Flex Hub Puller Bolt Holes for Reduced Shank Diameter Hubs — Millimeters**

SIZE ★	Millimeters			SIZE ★	Millimeters		
	N	B.C.	Tap Size (in)		N	B.C.	Tap Size (in)
<b>1160/2160G</b>	647,7	571,5	1.500-6 UNC	<b>1240/2240G</b>	1 054,1	927,1	2-4.5 UNC
	527,0	450,8			863,6	749,3	
<b>1180/2180G</b>	749,3	660,4	1.500-6 UNC	<b>1260/2260G</b>	1 155,7	1 028,7	2-4.5 UNC
	609,6	520,7			946,1	819,2	
<b>1200/2200G</b>	850,9	749,3	2-4.5 UNC	<b>1280/2280G</b>	1 257,3	1 130,3	2-4.5 UNC
	692,2	590,6			1 035,0	908,0	
<b>1220/2220G</b>	952,5	838,2	2-4.5 UNC	<b>1300/2300G</b>	1 358,9	1 231,9	2-4.5 UNC
	781,1	666,8			1 117,6	990,6	

# Engineering Data — Large Flanged Sleeve

## Standard Filleted Keyways & Chamfered Keys

Fillets are standard in metric keyways. If fillets are required in inch keyways, refer to the Factory for recommendations.

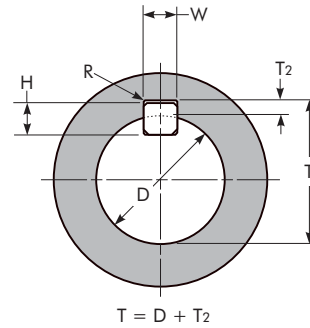

**TABLE 33 — Standard Filleted Keyways & Chamfered Keys — Millimeters**

Nominal Bore		Key		Hub Keyway			
Over	Thru	Size (Nominal)	45° Chamfer Suggested	Width		Depth ♦	Fillet Radii
95	110	28 x 16	0,70	28	+/-0,0260	6,4 / 6,6	0,60
110	130	32 x 18	0,70	32	+/-0,0260	7,4 / 7,6	0,60
130	150	36 x 20	1,10	36	+/-0,0260	8,4 / 8,7	1,00
150	170	40 x 22	1,10	40	+/-0,0260	9,4 / 9,7	1,00
170	200	45 x 25	1,10	45	+/-0,0260	10,4 / 10,7	1,00
200	230	50 x 28	1,10	50	+/-0,0260	11,4 / 11,7	1,00
230	260	56 x 32	1,80	56	+/-0,0260	12,4 / 12,7	1,60
260	290	63 x 32	1,80	63	+/-0,0260	12,4 / 12,7	1,60
290	330	70 x 36	1,80	70	+/-0,0260	14,4 / 14,7	1,60
330	380	80 x 40	2,70	80	+/-0,0260	15,4 / 15,7	2,50
380	440	90 x 45	2,70	90	+/-0,0260	17,4 / 17,7	2,50
440	500	100 x 50	2,70	100	+/-0,0260	19,5 / 19,8	2,50

♦ Shallow keyway depth must equal or exceed  $\frac{2}{3}$  of the full keyway depth of the square keys shown above.

# Engineering Data — Large Flanged Sleeve

## Double Engagement Couplings

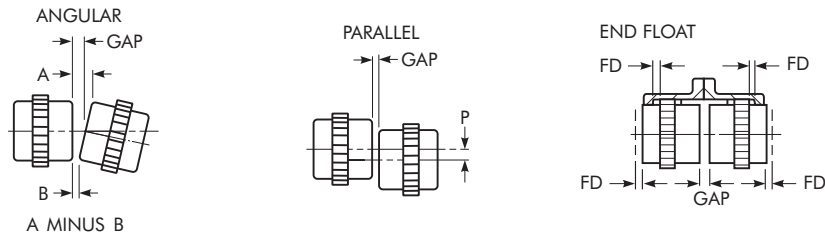

**TABLE 34 — Misalignment & End Float – Double Engagement Couplings**

SIZE	Angular Misalignment Limits						Parallel Misalignment Limits						End Float		
	Installation		Operating *		Static *		Installation		Operating *		Static *		Std FD Min (mm)	Normal Gap +/-10% (mm)	Physical Limit Min (2) FD + Gap (mm)
	A Minus B (mm)	Degrees Per Mesh	A Minus B (mm)	Degrees Per Mesh	A Minus B (mm)	Degrees Per Mesh	P (mm)	Degrees Per Mesh	P (mm)	Degrees Per Mesh	P (mm)	Degrees Per Mesh			
1080/2080	0,81	1/16°	4,83	3/8°	9,65	3/4°	0,41	1/16°	2,46	3/8°	4,90	3/4°	4,32	10	18
1090/2090	0,91	1/16°	5,49	3/8°	10,97	3/4°	0,43	1/16°	2,64	3/8°	5,23	3/4°	6,30	13	25
1100/2100	1,02	1/16°	6,15	3/8°	12,29	3/4°	0,48	1/16°	2,97	3/8°	5,94	3/4°	6,30	13	25
1110/2110	1,14	1/16°	6,81	3/8°	13,64	3/4°	0,56	1/16°	3,30	3/8°	6,58	3/4°	6,30	13	25
1120/2120	1,24	1/16°	7,49	3/8°	14,99	3/4°	0,58	1/16°	3,51	3/8°	7,04	3/4°	6,30	13	25
1130/2130	1,32	1/16°	7,98	3/8°	15,95	3/4°	0,61	1/16°	3,61	3/8°	7,24	3/4°	8,76	19	37
1140/2140	1,45	1/16°	8,64	3/8°	17,30	3/4°	0,64	1/16°	3,81	3/8°	7,59	3/4°	8,76	19	37
1150/2150	1,55	1/16°	9,32	3/8°	18,62	3/4°	0,69	1/16°	4,17	3/8°	8,33	3/4°	8,76	19	37
1160/2160	1,60	1/16°	9,65	3/8°	19,28	3/4°	0,71	1/16°	4,22	3/8°	8,41	3/4°	11,68	25	49
1180/2180	1,83	1/16°	10,97	3/8°	21,95	3/4°	0,74	1/16°	4,37	3/8°	8,74	3/4°	11,68	25	49
1200/2200	2,03	1/16°	12,14	3/8°	24,28	3/4°	0,89	1/16°	5,28	3/8°	10,57	3/4°	11,68	25	49
1220/2220	2,21	1/16°	13,31	3/8°	26,59	3/4°	0,99	1/16°	5,87	3/8°	11,73	3/4°	11,68	25	49
1240/2240	2,46	1/16°	14,78	3/8°	29,59	3/4°	1,07	1/16°	6,40	3/8°	12,80	3/4°	11,68	25	49
1260/2260	2,69	1/16°	16,13	3/8°	32,46	3/4°	1,17	1/16°	6,93	3/8°	13,89	3/4°	11,68	25	49
1280/2280	2,92	1/16°	17,45	3/8°	34,90	3/4°	1,19	1/16°	7,14	3/8°	14,30	3/4°	11,68	25	49
1300/2300	3,12	1/16°	18,80	3/8°	37,57	3/4°	1,22	1/16°	7,37	3/8°	14,71	3/4°	11,68	25	49

† These maximum operating alignment limits are each based on 3/8° per flex half coupling. Combined values of parallel and angular misalignment should not exceed 3/8°. Type GL slide couplings are limited to 1/4° per flex half. Application requirements in excess of these values should be referred to the the Factory for review.

**TABLE 35 — Misalignment & End Float – Single Engagement Couplings**

SIZE	Angular Misalignment Limits *						End Float			
	Installation		Operating		Static		Std FD Min (mm)	Normal Shaft Gap (mm)	Normal Face Gap (X) (mm)	Physical Limit Min FD + Gap (mm)
	A Minus B (mm)	Degrees Per Mesh	A Minus B (mm)	Degrees Per Mesh	A Minus B (mm)	Degrees Per Mesh				
1080/2080	0,81	1/8°	2,41	3/8°	4,83	3/4°	4,57	13	5	17
1090/2090	0,91	1/8°	2,74	3/8°	5,49	3/4°	6,55	14	6	21
1100/2100	1,02	1/8°	3,07	3/8°	6,15	3/4°	6,48	16	6	22
1110/2110	1,14	1/8°	3,40	3/8°	6,81	3/4°	6,48	16	6	22
1120/2120	1,24	1/8°	3,73	3/8°	7,49	3/4°	6,48	16	6	22
1130/2130	1,32	1/8°	3,99	3/8°	7,98	3/4°	8,64	19	9	28
1140/2140	1,45	1/8°	4,32	3/8°	8,64	3/4°	8,64	19	9	28
1150/2150	1,55	1/8°	4,65	3/8°	9,32	3/4°	8,64	19	9	28
1160/2160	1,60	1/8°	4,83	3/8°	9,65	3/4°	11,43	25	13	37
1180/2180	1,83	1/8°	5,49	3/8°	10,97	3/4°	11,43	25	13	37
1200/2200	2,03	1/8°	6,07	3/8°	12,14	3/4°	11,43	25	13	37
1220/2220	2,21	1/8°	6,65	3/8°	13,31	3/4°	11,43	29	13	40
1240/2240	2,46	1/8°	7,39	3/8°	14,78	3/4°	11,43	29	13	40
1260/2260	2,69	1/8°	8,05	3/8°	16,13	3/4°	11,43	29	13	40
1280/2280	2,92	1/8°	8,74	3/8°	17,45	3/4°	11,30	29	13	40
1300/2300	3,12	1/8°	9,40	3/8°	18,80	3/4°	11,30	29	13	40

\* Do not use single engagement couplings to compensate for parallel offset misalignment.

## Single Engagement Couplings

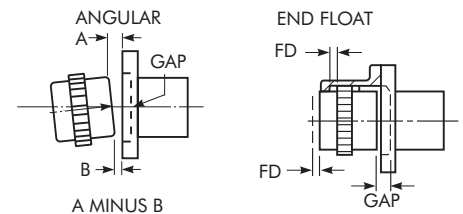

# Engineering Data — All Gear Couplings

**TABLE 36 — Recommended Bores for Metric Shafts – Millimeters (Per ISO/R775–1969)**

	Shaft Diameter	Clearance Fit		Transitional Fit		Interference Fit	
		Hub Bore	Fit ♦	Hub Bore	Fit ♦	Hub Bore	Fit ♦
	<b>i6</b> +0,008 / -0,003	<b>F7</b> +0,016 / +0,034	+0,008 +0,037	<b>H7</b> +0,000 / +0,018	-0,008 +0,021	<b>M6</b> -0,015 / -0,064	-0,023 -0,001
12	12,008 / 11,997	12,016 / 12,034	↓	12,000 / 12,018	↓	11,985 / 11,996	↓
14	14,008 / 13,997	14,016 / 14,034	↓	14,000 / 14,018	↓	13,985 / 13,996	↓
16	16,008 / 15,997	16,016 / 16,034	↓	16,000 / 16,018	↓	15,985 / 15,996	↓
18	18,008 / 17,997	18,016 / 18,034	↓	18,000 / 18,018	↓	17,985 / 17,996	↓
	<b>i6</b> 0,009 / -0,004	<b>F7</b> +0,020 / +0,041	+0,011 +0,045	<b>H7</b> +0,000 / +0,021	-0,009 +0,025	<b>M6</b> -0,017 / -0,004	-0,026 +0,000
19	19,009 / 18,996	19,020 / 19,041	↓	19,000 / 19,021	↓	18,983 / 18,996	↓
20	20,009 / 19,996	20,020 / 20,041	↓	20,000 / 20,021	↓	19,983 / 19,996	↓
22	22,009 / 21,996	22,020 / 22,041	↓	22,000 / 22,021	↓	21,983 / 21,996	↓
24	24,009 / 23,996	24,020 / 24,041	↓	24,000 / 24,021	↓	23,983 / 23,996	↓
25	25,009 / 24,996	25,020 / 25,041	↓	25,000 / 25,021	↓	24,983 / 24,996	↓
28	28,009 / 27,996	28,020 / 28,041	↓	28,000 / 28,021	↓	27,983 / 27,996	↓
30	30,008 / 29,996	30,020 / 30,041	↓	30,000 / 30,021	↓	29,983 / 29,996	↓
> 30	<b>k6</b> +0,018 / +0,002	<b>F7</b> +0,025 / +0,050	+0,007 +0,048	<b>H7</b> +0,000 / +0,025	-0,018 +0,023	<b>K6</b> -0,013 / +0,003	-0,031 +0,001
32	32,018 / 32,002	32,025 / 32,050	↓	32,000 / 32,025	↓	31,987 / 32,003	↓
35	35,018 / 35,002	32,025 / 32,050	↓	35,000 / 35,025	↓	34,987 / 35,003	↓
38	38,018 / 38,002	38,025 / 38,050	↓	38,000 / 38,025	↓	37,987 / 38,003	↓
40	40,018 / 40,002	40,025 / 40,050	↓	40,000 / 40,025	↓	39,987 / 40,003	↓
42	42,018 / 42,002	42,025 / 42,050	↓	42,000 / 42,025	↓	41,987 / 42,003	↓
45	45,018 / 45,002	45,025 / 45,050	↓	45,000 / 45,025	↓	44,987 / 45,003	↓
48	48,018 / 48,002	48,025 / 48,050	↓	48,000 / 48,025	↓	47,987 / 48,003	↓
50	50,018 / 50,002	50,025 / 50,050	↓	50,000 / 50,025	↓	49,987 / 50,003	↓
> 50	<b>m6</b> +0,030 / +0,011	<b>F7</b> +0,030 / +0,060	+0,000 +0,049	<b>H7</b> +0,000 / +0,030	-0,030 +0,019	<b>K7</b> -0,021 / +0,009	-0,051 -0,002
55	55,030 / 55,011	55,030 / 55,060	↓	55,000 / 55,030	↓	54,979 / 55,009	↓
56	56,030 / 56,011	56,030 / 56,060	↓	56,000 / 56,030	↓	55,979 / 56,009	↓
60	60,030 / 60,011	60,030 / 60,060	↓	60,000 / 60,030	↓	59,979 / 60,009	↓
63	63,030 / 63,011	63,030 / 63,060	↓	63,000 / 63,030	↓	62,979 / 63,009	↓
65	65,030 / 65,011	65,030 / 65,060	↓	65,000 / 65,030	↓	64,979 / 65,009	↓
70	70,030 / 70,011	70,030 / 70,060	↓	70,000 / 70,030	↓	69,979 / 70,009	↓
71	71,030 / 71,011	71,030 / 71,060	↓	71,000 / 71,030	↓	70,979 / 71,009	↓
75	75,030 / 75,011	75,030 / 75,060	↓	75,000 / 75,030	↓	74,979 / 75,009	↓
80	80,030 / 80,011	80,030 / 80,060	↓	80,000 / 80,030	↓	79,979 / 80,009	↓
> 80	<b>m6</b> +0,035 / +0,013	<b>F7</b> +0,036 / +0,071	+0,001 +0,058	<b>H7</b> +0,000 / +0,035	-0,035 +0,022	<b>M7</b> -0,035 / +0,000	-0,070 -0,013
85	85,035 / 85,013	85,036 / 85,071	↓	85,000 / 85,035	↓	84,965 / 85,000	↓
90	90,035 / 90,013	90,036 / 90,071	↓	90,000 / 90,035	↓	89,965 / 90,000	↓
95	95,035 / 95,013	95,036 / 95,071	↓	95,000 / 95,035	↓	94,965 / 95,000	↓
100	100,035 / 100,013	100,036 / 100,071	↓	100,000 / 100,035	↓	99,965 / 100,000	↓
> 100	<b>m6</b> +0,035 / +0,013	<b>F7</b> +0,036 / +0,071	↓	<b>H7</b> +0,000 / +0,035	↓	<b>P7</b> -0,059 / -0,024	-0,094 -0,037
110	100,035 / 110,013	110,036 / 110,071	↓	110,000 / 110,035	↓	109,941 / 109,976	↓
120	120,035 / 120,013	120,036 / 120,071	↓	120,000 / 120,035	↓	119,941 / 119,976	↓
> 120	<b>m6</b> 0,040 / +0,015	<b>F7</b> +0,043 / +0,083	+0,003 +0,068	<b>H7</b> +0,000 / +0,040	-0,040 +0,025	<b>P7</b> -0,068 / -0,028	-0,108 -0,043
125	125,040 / 125,015	125,043 / 125,083	↓	125,000 / 125,040	↓	124,932 / 124,972	↓
130	130,040 / 130,015	130,043 / 130,083	↓	130,000 / 130,040	↓	129,932 / 129,972	↓
140	140,040 / 140,015	140,043 / 140,083	↓	140,000 / 140,040	↓	139,932 / 139,972	↓
150	150,040 / 150,015	150,043 / 150,083	↓	150,000 / 150,040	↓	149,932 / 149,972	↓
160	160,040 / 160,015	160,043 / 160,083	↓	160,000 / 160,040	↓	159,932 / 159,972	↓
170	170,040 / 170,015	170,043 / 170,083	↓	170,000 / 170,040	↓	169,932 / 169,972	↓
180	180,040 / 180,015	180,043 / 180,083	↓	180,000 / 180,040	↓	179,932 / 179,972	↓

♦ Positive values are clearance, negative values are interference.

Continued on Page 57



# Engineering Data — All Gear Couplings

**TABLE 36 — Recommended Bores for Metric Shafts – Millimeters (Per ISO/R775–1969) – Cont.**

	Shaft Diameter	Clearance Fit		Transitional Fit		Interference Fit	
		Hub Bore	Fit*	Hub Bore	Fit*	Hub Bore	Fit*
> 180	<b>m6</b> +0,046 / +0,017	<b>F7</b> +0,050 / +0,096	+0,004 +0,079	<b>H7</b> +0,000 / +0,046	-0,046 +0,029	<b>P7</b> -0,079 / -0,033	-0,125 -0,050
	190 190,046 / 190,017	190,050 / 190,096	↓	190,000 / 190,460	↓	189,921 / 189,967	↓
	200 200,046 / 200,017	200,050 / 200,096	↓	200,000 / 200,046	↓	199,921 / 199,967	↓
> 200	<b>m6</b> +0,046 / +0,017	<b>F7</b> +0,050 / +0,096	↓	<b>H7</b> +0,000 / +0,046	↓	<b>R7</b> -0,109 / -0,063	-0,155 -0,080
	210 210,046 / 210,017	210,050 / 210,096	↓	210,000 / 210,046	↓	209,891 / 209,937	↓
	220 220,046 / 220,017	220,050 / 220,096	↓	220,000 / 220,046	↓	219,891 / 219,937	↓
	225 225,046 / 225,017	225,050 / 225,096	↓	225,000 / 225,046	↓	224,891 / 224,937	↓
> 225	<b>m6</b> +0,046 / +0,017	<b>F7</b> +0,050 / +0,096	↓	<b>H7</b> +0,000 / +0,046	↓	<b>R7</b> -0,113 / -0,067	-0,159 -0,084
	230 230,046 / 230,017	230,050 / 230,096	↓	230,000 / 230,046	↓	229,887 / 229,933	↓
	240 240,046 / 240,017	240,050 / 240,096	↓	240,000 / 240,046	↓	239,887 / 239,933	↓
	250 250,046 / 250,017	250,050 / 250,096	↓	250,000 / 250,046	↓	249,887 / 249,933	↓
> 250	<b>m6</b> +0,052 / +0,020	<b>F7</b> +0,056 / +0,108	+0,004 +0,088	<b>H7</b> +0,000 / +0,052	-0,052 +0,032	<b>R7</b> -0,126 / -0,074	-0,178 -0,094
	260 260,052 / 260,020	260,056 / 260,108	↓	260,000 / 260,052	↓	259,874 / 259,926	↓
	270 270,052 / 270,020	270,056 / 270,108	↓	270,000 / 270,052	↓	269,874 / 269,926	↓
	280 280,052 / 280,020	280,056 / 280,108	↓	280,000 / 280,052	↓	279,874 / 279,926	↓
> 280	<b>m6</b> +0,052 / +0,020	<b>F7</b> +0,056 / +0,108	↓	<b>H7</b> +0,000 / +0,052	↓	<b>R7</b> -0,130 / -0,078	-0,182 -0,098
	290 290,052 / 290,020	290,056 / 290,108	↓	290,000 / 290,052	↓	289,870 / 289,922	↓
	300 300,052 / 300,020	300,056 / 300,108	↓	300,000 / 300,052	↓	299,870 / 299,922	↓
	310 310,052 / 310,020	310,056 / 310,108	↓	310,000 / 310,052	↓	309,870 / 309,922	↓
	315 315,052 / 315,020	315,056 / 315,108	↓	315,000 / 315,052	↓	314,870 / 314,922	↓
> 315	<b>m6</b> +0,057 / +0,021	<b>F7</b> +0,062 / +0,119	+0,005 +0,098	<b>H7</b> +0,000 / +0,057	-0,057 +0,036	<b>R7</b> -0,144 / -0,187	-0,201 -0,108
	320 320,057 / 320,021	320,062 / 320,119	↓	320,000 / 320,057	↓	319,856 / 319,913	↓
	330 330,057 / 330,021	330,062 / 330,119	↓	330,000 / 330,057	↓	329,856 / 329,913	↓
	340 340,057 / 340,021	340,062 / 340,119	↓	340,000 / 340,057	↓	339,856 / 339,913	↓
	350 350,057 / 350,021	350,062 / 350,119	↓	350,000 / 350,057	↓	349,856 / 349,913	↓
	355 355,057 / 355,021	355,062 / 355,119	↓	355,000 / 355,057	↓	354,856 / 354,913	↓
> 355	<b>m6</b> +0,057 / +0,021	<b>F7</b> +0,062 / +0,119	↓	<b>H7</b> +0,000 / +0,057	↓	<b>R8</b> -0,203 / -0,114	-0,260 -0,136
	360 360,057 / 360,021	360,062 / 360,119	↓	360,000 / 360,057	↓	359,797 / 359,886	↓
	370 370,057 / 370,021	370,062 / 370,119	↓	370,000 / 370,057	↓	369,797 / 369,886	↓
	380 380,057 / 380,021	380,062 / 380,119	↓	380,000 / 380,057	↓	379,797 / 379,886	↓
	390 390,057 / 390,021	390,062 / 390,119	↓	390,000 / 390,057	↓	389,797 / 389,886	↓
	400 400,057 / 400,021	400,062 / 400,119	↓	400,000 / 400,057	↓	399,797 / 399,886	↓
> 400	<b>m6</b> +0,063 / +0,023	<b>F7</b> +0,068 / +0,131	+0,005 +0,108	<b>H7</b> +0,000 / +0,063	-0,063 +0,040	<b>R8</b> -0,223 / -0,126	-0,286 -0,149
	410 410,063 / 410,023	410,068 / 410,131	↓	410,000 / 410,063	↓	409,777 / 409,874	↓
	420 420,063 / 420,023	420,068 / 420,131	↓	420,000 / 420,063	↓	419,777 / 419,874	↓
	430 430,063 / 430,023	430,068 / 430,131	↓	430,000 / 430,063	↓	429,777 / 429,874	↓
	440 440,063 / 440,023	440,068 / 440,131	↓	440,000 / 440,063	↓	439,777 / 439,874	↓
	450 450,063 / 450,023	450,068 / 450,131	↓	450,000 / 450,063	↓	449,777 / 449,874	↓
> 450	<b>m6</b> +0,063 / +0,023	<b>F7</b> +0,068 / +0,131	↓	<b>H7</b> +0,000 / +0,063	↓	<b>R8</b> -0,229 / -0,132	-0,292 -0,155
	460 460,063 / 460,023	460,068 / 460,131	↓	460,000 / 460,063	↓	459,771 / 459,868	↓
	470 470,063 / 470,023	470,068 / 470,131	↓	470,000 / 470,063	↓	469,771 / 469,868	↓
	480 480,063 / 480,023	480,068 / 480,131	↓	480,000 / 480,063	↓	479,771 / 479,868	↓
	490 490,063 / 490,023	490,068 / 490,131	↓	490,000 / 490,063	↓	489,771 / 489,868	↓
	500 500,063 / 500,023	500,068 / 500,131	↓	500,000 / 500,063	↓	499,771 / 499,868	↓

♦ Positive values are clearance, negative values are interference.

# Interchange Guide ♦ — Flanged Sleeve Gear Couplings

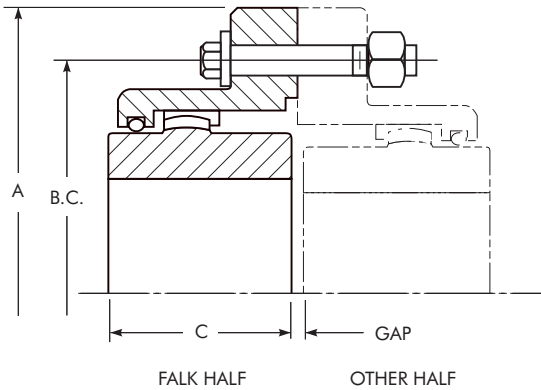

Exposed Bolt — Falk G20 (1000 Series) Half & Other Half

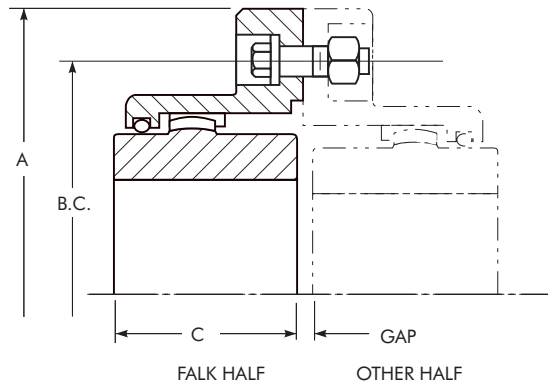

Shrouded Bolt — Falk G10 (1000 Series) Half & Other Half

## Exposed & Shrouded Bolts

Common Dimensions						Falk G20 Exposed & Falk G10 Shrouded (1000 Series)				Falk GF Steel Mill Exposed & Shrouded				Lovejoy® Sier-Bath-F® Exposed & Shrouded				Falk G20 Exposed & Falk G20 Shrouded (10 Series)				
A	Exposed		Shrouded		Gap	SIZE	Torque Rating (lb-in)	Max Bore Std Key	C	SIZE	Torque Rating (lb-in)	Max Bore	C	SIZE	Torque Rating (lb-in)	Max Bore	C	SIZE	Torque Rating (lb-in)	Max Bore	C	
	B.C.	Cap Screw Size & Qty	B.C.	Cap Screw Size & Qty																		
4.562	3.562	6-312	3.562	6-312	.125	...	...	...	...	...	...	...	...	...	...	...	...	...	...	...	...	...
4.562	3.750	6-250	3.750	6-250	.125	<b>1010G</b>	10,800	1.875	1.69	<b>1GF</b>	7,600	1.625	1.69	<b>F-1</b>	7,560	1.625	1.687	<b>10G</b>	5,040	1.375	1.500	
6.000	4.812	8-375	4.812	8-375	.125	<b>1015G</b>	20,790	2.375	1.94	<b>1-1/2GF</b>	18,900	2.125	1.94	<b>F-1 1/2</b>	18,900	2.125	1.937	<b>15G</b>	15,120	2.125	2.000	
7.000	5.875	6-500	5.812	10-375	.125	<b>1020G</b>	37,800	2.875	2.44	<b>2GF</b>	31,500	2.750	2.44	<b>F-2</b>	31,500	2.750	2.437	<b>20G</b>	31,500	2.625	2.437	
8.375	7.125	6-625	7.000	10-500	.187	<b>1025G</b>	66,150	3.625	3.03	<b>2-1/2GF</b>	56,700	3.250	3.03	<b>F-2 1/2</b>	56,700	3.250	3.031	<b>25G</b>	56,700	3.250	3.031	
9.437	8.125	8-625	8.000	12-500	.187	<b>1030G</b>	107,100	4.125	3.59	<b>3GF</b>	101,000	4.000	3.59	<b>F-3</b>	94,500	4.000	3.593	<b>30G</b>	94,500	3.750	3.593	
11.000	9.500	8-750	9.281	12-625	.250	<b>1035G</b>	163,800	4.875	4.19	<b>3-1/2GF</b>	151,300	4.500	4.19	<b>F-3 1/2</b>	151,200	4.500	4.187	<b>35G</b>	126,000	4.500	4.187	
12.500	11.000	8-750	10.625	14-625	.125	<b>1040G</b>	270,900	5.750	4.75	<b>4GF</b>	236,000	5.375	4.75	<b>F-4</b>	220,500	5.375	4.750	<b>40G</b>	189,000	5.125	4.750	
13.625	12.000	10-750	11.750	14-625	.312	<b>1045G</b>	371,700	6.750	5.31	<b>4-1/2GF</b>	324,000	6.500	5.31	<b>F-4 1/2</b>	302,400	6.500	5.312	<b>45G</b>	267,750	5.500	5.312	
15.312	13.500	8-875	13.187	14-750	.312	<b>1050G</b>	500,900	7.375	6.03	<b>5GF</b>	441,000	7.000	6.03	<b>F-5</b>	434,700	7.000	6.031	<b>50G</b>	368,550	6.375	6.031	
16.750	14.500	14-875	14.437	16-750	.312	<b>1055G</b>	655,200	8.250	6.62	<b>5-1/2GF</b>	580,000	7.750	6.91	<b>F-5 1/2</b>	573,300	7.750	6.906	<b>55G</b>	491,400	7.250	6.625	
18.000	15.750	14-875	NA	NA	.312	<b>1060G</b>	800,100	9.125	7.41	<b>6GF</b>	759,000	8.750	7.41	<b>F-6</b>	749,700	8.750	7.406	<b>60G</b>	630,000	8.250	7.375	

## Exposed & Shrouded Bolts (Continued)

Kop-Flex® (Koppers) HM (Exposed) HS (Shrouded)				Kop-Flex (Fast)® EB (Exposed) SB (Shrouded)				Kop-Flex (Waldron)® EB (Exposed) SB (Shrouded)				Zurn® Amerigear-F Exposed & Shrouded (200 Series)				Renold® Metal Seal Exposed & Shrouded			
SIZE	Torque Rating (lb-in)	Max Bore	C	SIZE	Torque Rating (lb-in)	Max Bore	C	SIZE	Torque Rating (lb-in)	Max Bore	C	SIZE	Torque Rating (lb-in)	Max Bore	C	SIZE	Torque Rating (lb-in)	Max Bore	C
<b>1HM/HS</b>	7,560	1.625	1.687	...	...	...	...	<b>1EB/SB</b>	6,300	1.625	1.687	...	...	...	...	...	...	...	...
<b>1-1/2HM/HS</b>	17,010	2.250	1.937	<b>1-1/2EB/SB</b>	17,010	1.625	1.937	<b>1-1/2EB/SB</b>	15,120	2.187	2.062	<b>F201-1/2</b>	17,010	2.250	1.937	<b>1-1/2</b>	2,016	1.750	1.937
<b>2HM/HS</b>	31,500	2.750	2.437	<b>2EB/B</b>	31,500	2.125	2.437	<b>2EB/SB</b>	31,500	2.750	2.437	<b>F202</b>	31,500	2.750	2.437	<b>2</b>	34,650	2.250	2.437
<b>2-1/2HM/HS</b>	56,700	3.500	3.031	<b>2-1/2EB/SB</b>	56,700	2.750	3.031	<b>2-1/2EB/SB</b>	56,700	3.250	3.031	<b>F202-1/2</b>	53,550	3.500	3.031	<b>2-1/2</b>	59,850	2.750	3.031
<b>3HM/HS</b>	88,200	4.000	3.593	<b>3EB/B</b>	100,800	3.125	3.593	<b>3EB/SB</b>	94,500	4.000	3.593	<b>F203</b>	94,500	4.000	3.593	<b>3</b>	99,540	3.250	3.593
<b>3-1/2HM/HS</b>	129,150	4.500	4.187	<b>3-1/2EB/SB</b>	148,050	3.750	4.187	<b>3-1/2EB/SB</b>	144,900	4.750	4.187	<b>F203-1/2</b>	141,750	4.500	4.187	<b>3-1/2</b>	149,940	3.750	4.187
<b>4HM/HS</b>	204,750	5.500	4.750	<b>4EB/B</b>	236,250	4.250	4.750	<b>4EBSB</b>	220,500	5.375	4.750	<b>F204</b>	214,200	5.500	4.750	<b>4</b>	269,640	4.250	4.750
<b>4-1/2HM/HS</b>	277,200	6.000	5.312	<b>4-1/2EB/SB</b>	318,150	4.750	5.312	<b>4-1/2EBSB</b>	302,400	6.000	5.375	<b>F204-1/2</b>	324,450	6.250	5.312	<b>4-1/2</b>	369,810	4.750	5.312
<b>5HM/HS</b>	384,300	6.875	6.031	<b>5EB/B</b>	441,000	5.500	6.031	<b>5EB/SB</b>	409,500	7.000	6.125	<b>F205</b>	415,800	6.750	6.031	<b>5</b>	499,590	5.500	6.031
<b>5-1/2HM/HS</b>	504,000	7.750	6.906	<b>5-1/2EB/SB</b>	579,600	5.875	6.906	<b>5-1/2EB/SB</b>	535,500	7.750	6.625	<b>F205-1/2</b>	551,250	7.620	6.625	<b>5-1/2</b>	650,160	6.250	6.906
<b>6HM</b>	661,500	8.625	7.406	<b>6EB</b>	759,150	6.500	7.406	<b>6EB</b>	693,000	8.750	7.375	<b>F206</b>	749,700	8.620	7.406	<b>6</b>	749,700	7.375	7.406
<b>7HM</b>	1,008,000	10.375	8.687	<b>7EB</b>	1,159,200	8.000	8.687	<b>7EB</b>	1,010,000	9.750	8.687	<b>F207</b>	1,033,200	10.250	8.687	<b>7</b>	926,100	8.750	8.687

□ Based on the original Sier-Bath design. Component parts are interchangeable.

♦ Competitive complete half couplings are interchangeable because O.D., bolt circle, quantity and size are the same.

# Interchange Guide — Continuous Sleeve Gear Couplings ▲

SIZE	Max Bore	Torque (lb-in)	RPM ♦	O.D.	Overall Length	Gap	SIZE	Max Bore	Torque (lb-in)	RPM	O.D.	Overall Length	Gap	SIZE	Max Bore	Torque (lb-in)	RPM	O.D.	Overall Length	Gap
<b>Falk</b>							<b>Lovejoy Sier-Bath</b>							<b>Kop-Flex Waldron</b>						
1010GC	1.875	10,800	5,300	3.50	3.50	.125	7/8C	1.25	2,520	6,000	3.31	3.13	.125	1-1/8PL	1.250	2,520	14,000	2.94	3.00	.125
1015GC	2.375	20,790	4,300	4.30	4.08	.125	1-1/2C	1.63	7,560	5,000	3.75	3.75	.125	1-5/8PL	1.750	7,560	11,000	3.56	3.62	.125
1020GC	2.875	37,800	3,700	5.20	5.07	.125	2C	2.13	20,160	4,200	4.75	4.25	.125	1 1/2P	2.19	15,120	9,000	4.12	4.25	.125
1025GC	3.625	66,150	3,300	6.44	6.25	.188	2-1/2C	2.63	30,240	3,750	5.50	4.75	.250	2P	2.75	31,500	7,200	5.19	5.00	.125
1030GC	4.125	107,100	2,900	7.50	7.37	.188	3C	3.13	50,400	3,000	6.63	5.50	.250	2 1/2P	3.25	56,700	6,000	6.00	6.25	.188
1035GC	4.875	163,800	2,600	8.50	8.63	.250	3-1/2C	3.63	88,200	2,800	7.50	8.75	.250	3P	4.00	94,500	5,200	7.00	7.38	.188
...	...	...	...	...	...	...	4C	4.13	126,000	2,400	8.75	9.00	.250	3-1/2P	4.75	144,900	4,600	8.25	8.62	.250
...	...	...	...	...	...	...	4-1/2C	4.75	183,960	2,200	9.50	10.25	.250	4P	5.38	220,500	4,200	9.25	9.75	.250
...	...	...	...	...	...	...	5C	5.75	270,900	2,100	10.75	12.25	.250							
<b>Falk</b>							<b>Zurn</b>							<b>System Components</b>						
1010GC	1.875	10,800	5,300	3.50	3.50	.125	201CS	1.250	3,150	9,800	2.69	2.88	.125	8S	1.310	4,410	9,600	2.81	1.41	.094
1015GC	2.375	20,790	4,300	4.30	4.08	.125	201-1/4CS	1.625	7,560	8,900	3.19	3.50	.125	10S	1.630	9,765	7,560	3.44	1.84	.094
1020GC	2.875	37,800	3,700	5.20	5.07	.125	201-1/2CS	2.250	17,010	7,700	4.38	4.00	.125	12S	1.940	13,860	6,900	3.94	1.84	.094
1025GC	3.625	66,150	3,300	6.44	6.25	.188	202CS	2.750	31,500	6,200	5.38	5.00	.125	15S	2.130	19,530	6,600	4.13	2.78	.125
1030GC	4.125	107,100	2,900	7.50	7.37	.188	202-1/2CS	3.500	53,500	6,000	6.50	6.25	.188	20S	2.750	32,130	5,280	5.13	3.19	.125
1035GC	4.875	163,800	2,600	8.50	8.63	.250	203CS	4.000	94,500	5,200	7.44	7.37	.188	25S	3.250	56,700	4,500	6.03	3.88	.188
...	...	...	...	...	...	...	203-1/2CS	4.500	141,750	4,400	8.32	8.63	.250	30S	3.750	95,760	3,960	6.84	4.53	.188
...	...	...	...	...	...	...	204CS	5.500	214,200	3,550	9.86	9.75	.250	35S	4.250	151,200	3,480	7.88	5.41	.250
...	...	...	...	...	...	...								40S	5.000	226,800	2,940	9.13	5.59	.250
...	...	...	...	...	...	...								45S	5.500	333,900	2,640	10.41	6.66	.312

▲ Couplings are functionally interchangeable only; components are not interchangeable. Verify interchange against specific application selection criteria.  
 ♦ Consult the Factory for higher speeds.

# Coupling Application Data Sheet

Company \_\_\_\_\_  
Address \_\_\_\_\_  
\_\_\_\_\_  
\_\_\_\_\_

Date \_\_\_\_\_  
Phone \_\_\_\_\_  
Fax \_\_\_\_\_  
Response Req'd By \_\_\_\_\_  
Submitted By \_\_\_\_\_

### COUPLING DESIGN:

Disc  Grid  Gear  Elastomer   
Horizontally Mounted  Vertically Mounted

### COUPLING TYPE:

Close Coupled  Spacer  Other \_\_\_\_\_

### SECTION I — PRIME MOVER:

Type: Electric Motor   
Rating (hp, kW) \_\_\_\_\_

Engine  (No. of Cyl.) \_\_\_\_\_  
Diesel  Gasoline  Gas   
Base Speed (rpm) \_\_\_\_\_

Turbine   
Steam  Air  Gas   
Maximum Speed (rpm) \_\_\_\_\_

### SECTION II — APPLICATION DATA

Description \_\_\_\_\_

Load Characteristics:  
Unidirectional  Reversing   
Smooth  Light Shock  Heavy Shock   
Little Vibration  Med. Vibration  Hvy. Vibration

Duty Cycle: Continuous  Intermittent

Environmental Concerns (Temperature, Moisture, Dust, Corrosive Materials) \_\_\_\_\_

### SECTION III — COUPLING SELECTION DATA

hp/bhp/kW \_\_\_\_\_ Torque \_\_\_\_\_

Design Requirements: Balance Class \_\_\_\_\_

Coupling Speed \_\_\_\_\_ rpm

Weight \_\_\_\_\_  $WR^2$  \_\_\_\_\_

Stiffness \_\_\_\_\_

Distance Between Shaft Ends or Shaft Gap \_\_\_\_\_

Misalignment:

Driver Shaft Diameter \_\_\_\_\_ Key \_\_\_\_\_

Angular \_\_\_\_\_ Offset \_\_\_\_\_

Fit: Clearance  Interference  Other \_\_\_\_\_

Axial \_\_\_\_\_

Driven Shaft Diameter \_\_\_\_\_ Key \_\_\_\_\_

Fit: Clearance  Interference  Other \_\_\_\_\_

Specifications Applicable:

API-610  API-671  Others \_\_\_\_\_

Service Factor:

AGMA Recommended  Other \_\_\_\_\_

Competitive Data:

Make \_\_\_\_\_

Size & Type \_\_\_\_\_

Bores \_\_\_\_\_ & \_\_\_\_\_

Price \_\_\_\_\_

Additional Comments:

\_\_\_\_\_  
\_\_\_\_\_  
\_\_\_\_\_

SKETCH AREA																			

**THIS PAGE INTENTIONALLY LEFT BLANK**

# World Class Customer Service

For more than 100 years, the dedicated people of Rexnord have delivered excellence in quality and service to our customers around the globe. Rexnord is a trusted name when it comes to providing skillfully engineered products that improve productivity and efficiency for industrial applications worldwide. We are committed to exceeding customer expectations in every area of our business: product design, application engineering, operations, and customer service.

Because of our customer focus, we are able to thoroughly understand the needs of your business and have the resources available to work closely with you to reduce maintenance costs, eliminate redundant inventories and prevent equipment down time.

Rexnord represents the most comprehensive portfolio of power transmission and conveying components in the world with the brands you know and trust.

Lifalign and Rexnord are registered trademarks of Rexnord Industries, LLC. Falk is a trademark of Rexnord. All rights reserved.

## WORLDWIDE CUSTOMER SERVICE

### AUSTRALIA

Rexnord Australia Pty. Ltd.  
Picton, New South Wales  
Phone: 61-2-4677-3811  
Fax: 61-2-4677-3812

### BRAZIL

Rexnord Correntes Ltda.  
Sao Leopoldo - RS  
Phone: 55-51-579-8022  
Fax: 55-51-579-8029

### CANADA

Rexnord Canada Ltd.  
Scarborough, Ontario  
Phone: 1-416-297-6868  
Fax: 1-416-297-6873

### CHINA

Rexnord China  
Shanghai, China  
Phone: 86-21-62701942  
Fax: 86-21-62701943

### EUROPE

Rexnord NV/SA  
Mechelen, Belgium  
Phone: 32-15-443811  
Fax: 32-15-443860

Rexnord Kette GmbH  
Betzdorf, Germany  
Phone: 49-2741-2840  
Fax: 49-2741-284-385

### LATIN AMERICA

Rexnord International, Inc.  
Milwaukee, Wisconsin  
Phone: 1-414-643-2366  
Fax: 1-414-643-3222  
E-mail: [international2@rexnord.com](mailto:international2@rexnord.com)

### MEXICO

Rexnord S.A. de C.V.  
Queretaro, Qro.  
Phone: 52-442-218.5000  
Fax: 52-.442-218-1090

### SINGAPORE

Rexnord International, Inc.  
Singapore City, Singapore  
Phone: 65-6338-5622  
Fax: 65-6338-5422

### UNITED STATES

Customer Service  
Phone: 1-866-REXNORD  
(1-866-739-6673)  
Fax: 1-614-675-1898  
E-mail: [rexnordcs\(state\)@rexnord.com](mailto:rexnordcs(state)@rexnord.com)  
Example: [rexnordcsohio@rexnord.com](mailto:rexnordcsohio@rexnord.com)

### ALL COUNTRIES NOT LISTED

Rexnord International  
Milwaukee, Wisconsin  
Phone: 1-414-643-2366  
Fax: 1-414-643-3222  
E-mail: [international1@rexnord.com](mailto:international1@rexnord.com)

