



ATLATOS®
THE TIMING BELT

CORREAS DENTADAS DE POLIURETANO



Soluciones de Movimiento

Correas dentadas ATLATOS®

Construcción

Las correas dentadas ATLATOS están fabricadas con poliuretano de alta calidad. Resistente a la abrasión con cables de tracción de acero y aramida de alta resistencia.

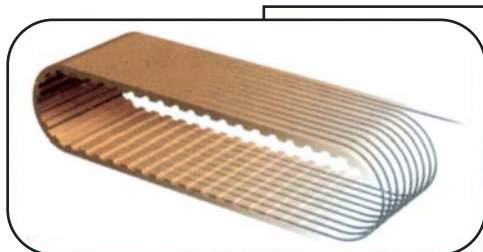

Propiedades

Dureza de 92 Shore A

Rango de temperatura -30° +80°

Cable interior de acero, inox o aramida

Correas sincrónicas de poliuretano sin fin

XL	
anchos standard (mm)	
9,53	
referencia	desarrollo (mm)
60	152,4
70	177,8
76	193,0
80	203,2
90	228,6
100	254,0
110	279,4
120	304,8
130	330,2
134	340,3
140	355,6
150	381,0
160	406,4
170	431,8
180	457,2
190	482,6
194	492,7
200	508,0
210	533,4
220	558,8
230	584,2
240	609,6
250	635,0
260	660,4
270	685,8
290	736,6
300	762,0
356	904,2
414	1051,5
450	1143,0
566	1437,6
670	1701,8

L	
anchos standard (mm)	
12,7/19,1/25,4	
referencia	desarrollo (mm)
124	314,3
150	381,0
187	476,2
202	514,4
210	533,4
225	571,5
240	609,6
255	647,7
270	685,8
285	723,9
300	762,0
322	817,9
345	876,3
367	933,4
390	990,6
420	1066,8
450	1143,0
480	1219,2
510	1295,4
540	1371,6
570	1447,8
600	1524,0

H	
anchos standard (mm)	
19,1/25,4/38,1/50,8/76,2	
referencia	desarrollo (mm)
230	584,2
240	609,6
255	647,7
270	685,8
300	762,0
330	838,2
360	914,4
390	990,6
420	1066,8
450	1143,0
480	1219,2
510	1295,4

Otras fabricaciones

MXL

3M 5M 8M 14M

STD 5M - STD 8M

RPP5 - RPP8
RPP14

P1 - P2 - P4

TG5 - TG10 - TG20

ATG10 - ATG20

T20 - AT20

Doble dentadas

Correas sincrónicas de poliuretano sin fin

T 2.5	
anchos standard (mm)	
6	
referencia	número dientes
120	48
145	58
160	64
177,5	71
182,5	73
200	80
210	84
230	92
245	98
265	106
285	114
290	116
305	122
317,5	127
330	132
380	152
420	168
480	192
500	200
540	216
600	240
620	248
650	260
680	272
780	312
880	352
915	366
950	380
1185	474

T 5	
anchos standard (mm)	
10/16/25	
referencia	número dientes
150	30
165	33
180	36
185	37
200	40
210	42
215	43
220	44
225	45
245	49
250	50
255	51
260	52
270	54
275	55
280	56
295	59
300	60
305	61
325	65
330	66
340	68
350	70
355	71
365	73
375	75
390	78
400	80
410	82
420	84
425	85
440	88
445	89

T 5	
anchos standard (mm)	
10/16/25	
referencia	número dientes
450	90
455	91
460	92
475	95
480	96
500	100
510	102
525	105
545	109
550	110
560	112
575	115
590	118
600	120
610	122
620	124
625	125
630	126
640	128
650	130
660	132
675	135
690	138
700	140
720	144
725	145
750	150
765	153
780	156
800	160
815	163
830	166
840	168
850	170
860	172
885	177
900	180
920	185
940	188
990	198
1000	200
1075	215
1100	220
1140	228
1160	232
1200	240
1215	243
1275	255
1280	256
1315	263
1350	270
1355	271
1380	276
1440	288
1580	316
1955	391

T 10	
anchos standard (mm)	
16/25/32/50	
referencia	número dientes
260	26
320	32
340	34
370	37
390	39
400	40
410	41
440	44
450	45
480	48
500	50
530	53
550	55
560	56
600	60
610	61
630	63
650	65
660	66
680	68
690	69
700	70
720	72
730	73
750	75
780	78
800	80
810	81
840	84
850	85
880	88
890	89
900	90
910	91
920	92
950	95
960	96
970	97
980	98
1000	100
1010	101
1050	105
1080	108
1100	110
1110	111
1140	114
1150	115
1200	120
1210	121
1240	124
1250	125
1300	130
1320	132
1350	135
1390	139
1400	140
1420	142
1440	144
1450	145
1460	146
1500	150
1560	156
1600	160
1610	161
1700	170
1750	175
1780	178
1800	180
1880	188
1960	196
2250	225

AT 5	
anchos standard (mm)	
10/16/25	
referencia	número dientes
225	45
255	51
280	56
300	60
330	66
340	68
375	75
390	78
420	84
450	90
455	91
480	96
500	100
525	105
545	109
600	120
610	122
630	126
660	132
710	142
720	144
750	150
780	156
825	165
860	172
975	195
1050	210
1125	225
1500	300
2000	400

AT 10	
anchos standard (mm)	
16/25/32/50	
referencia	número dientes
500	50
560	56
580	58
600	60
610	61
660	66
700	70
730	73
780	78
800	80
840	84
880	88
890	89
920	92
960	96
980	98
1000	100
1010	101
1050	105
1080	108
1100	110
1150	115
1200	120
1210	121
1250	125
1280	128
1300	130
1320	132
1350	135
1360	136
1400	140
1420	142
1480	148
1500	150
1600	160
1630	163
1700	170
1720	172
1800	180
1860	186
1940	194

Otras fabricaciones

RESISTENTES AL CALOR

200°C

CALIDAD ALIMENTARIA



CABLES INOX - KEVLAR

Correas abiertas a mts ATLATOS®

Programa de fabricación

TIPOS		ANCHOS STANDARD (Anchos intermedios tambien disponibles)														
MÉTRICO	Referencia	Paso	Milímetros:	6	8	10	12	16	25	32	50	75	100	125	150	
	T5	5mm		X		X		X	X	X	X	X	X			
	T10	10mm						X	X	X	X	X	X	X	X	
	T20	20 mm							X	X	X	X	X	X	X	
	AT5	5mm				X		X	X	X	X	X	X			
	AT10	10 mm						X	X	X	X	X	X		X	
	AT20	20 mm							X	X	X	X	X		X	
PULGADAS	Ref.	Paso mm.	Paso Pulg.	Código:	025	031	037	050	075	100	150	200	300	400	500	600
				Pulgadas:	1/4"	5/16"	3/8"	1/2"	3/4"	1"	1,5"	2"	3"	4"	5"	6"
				Milímetros:	6,35	7,94	9,53	12,7	19,05	25,4	38,1	50,8	76,2	101,6	127	152,4
	XL	5,080	1/5"		X	X	X	X	X	X						
	L	9,525	3/8"				X	X	X	X	X	X				
H	12,700	1/2"					X	X	X	X	X	X	X	X		
XH	22,225	7/8"							X	X	X	X	X	X		
MÉTRICO	Referencia	Paso	Milímetros:	10	15	20	25	30	40	50	55	85	100	115		
	HTD 5M	5 mm		X	X		X			X						
	HTD 8M	8 mm		X	X	X		X		X		X	X			
	HTD 14M	14 mm					X		X		X	X	X	X		
	RPP 5	5 mm		X	X		X			X						
	RPP 8	8 mm		X	X	X		X		X		X	X			
	RPP 14	14 mm					X		X		X	X	X	X		

Placas dentadas de aluminio



PASO

T5, AT5
T10, AT10
T20, AT20

PASO HTD

5M
8M
14M

PASO

XL
L
H

ACABADOS

Recubrimiento de tejido en los dientes.
(Menos ruido, Menor coef. rozamiento).

Recubrimiento de tejido en el lomo.
(Menor coef. rozamiento en el lomo).

Recubrimiento de tejido en ambos lados.

Cables de Alta Flexibilidad y Resistencia.

Cables de Kevlar.

Correa para transporte de paso T10 de hasta 350mm de anchura.

Correa para transporte de paso H de hasta 350mm de anchura.

Correa para transporte de paso 8M de hasta 350mm de anchura.

Fabricación con guía K interior.

Acabado en poliamida (PAZ - PAR).

Cable interior de acero, inox o kevlar.



Equivalencias de acabados entre marcas:

ATLATOS®

Correa a metros:	A/B	A	M	LL
Correa cerrada:	S/F	E	V	J
Tejido en los dientes:	PAZ	NT	PAZ	NFT
Tejido en el lomo:	PAR	NB	PAR	NFB
Tejido ambos lados:	PAZ/PAR	NTB	PAZ/PAR	NFTB
Recubrimiento uretano:	AUSF	HB	AUSF-T	AVAFC

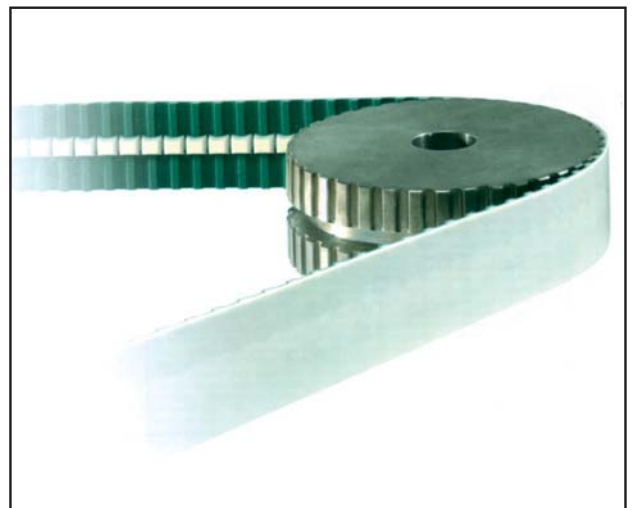
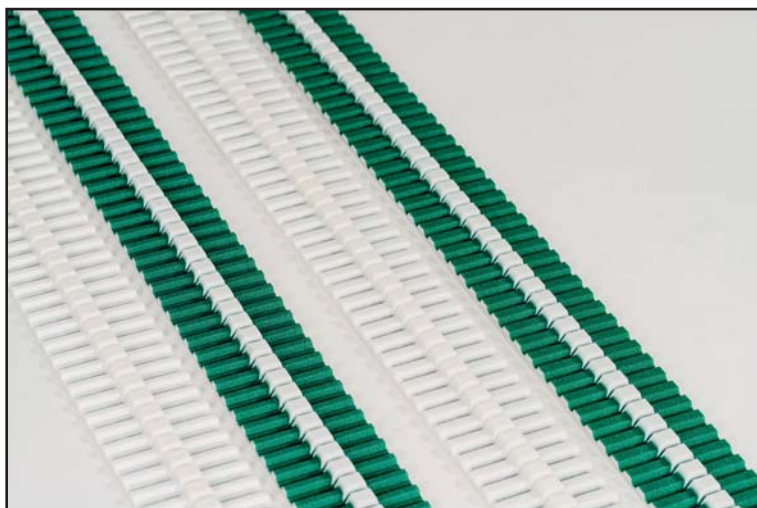

Correas dentadas ATLATOS® FLEX POWER

Correas dentadas sin-fin para transmisión de potencia

Correas dentadas ATLATOS® FLEX POWER sin empalme.

Funcionan tanto en régimen continuo como con arranques y paros.

El régimen de revoluciones es de hasta 10.000 min.⁻¹

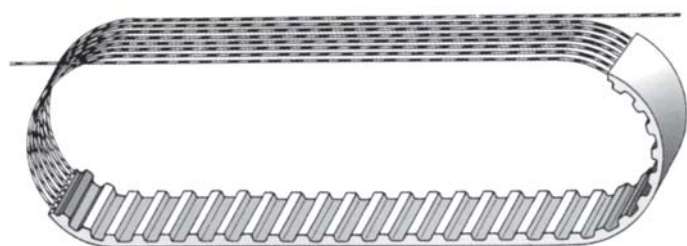

Longitudes de fabricación desde 1.740 mm hasta 24.000 mm

Calidad PU 92 Shore A

Cables de acero o inox.

Modelos de fabricación

H	T-5	AT-10
5M	T-10	ATL-10
8M	TL-10	AT-20
14M	T-20	



SOLUCIONES CON EMPALME

Correas unidas con grapas o pasadores.

Son ideales para un montaje y desmontaje rápido y sencillo.

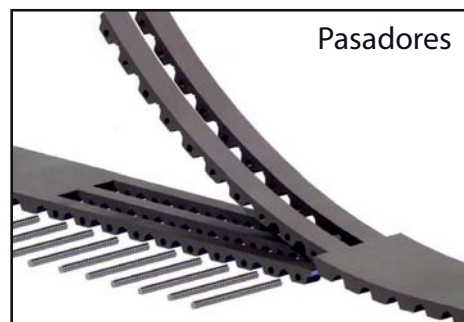
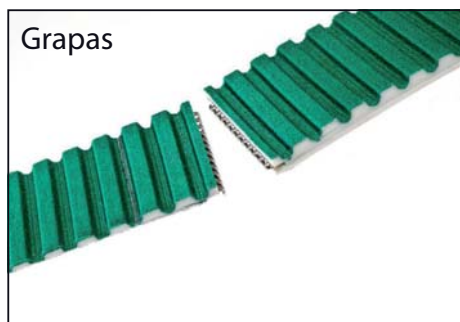
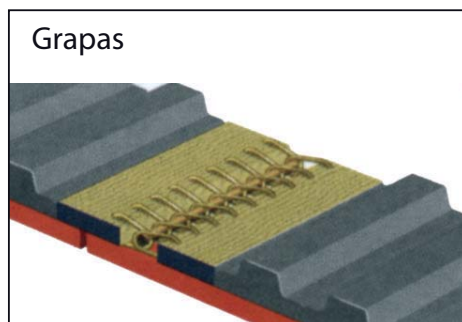

Correas soldadas para instalaciones de transporte.

Se pueden suministrar correas dentadas sin-fin soldadas, sin límite de desarrollo.

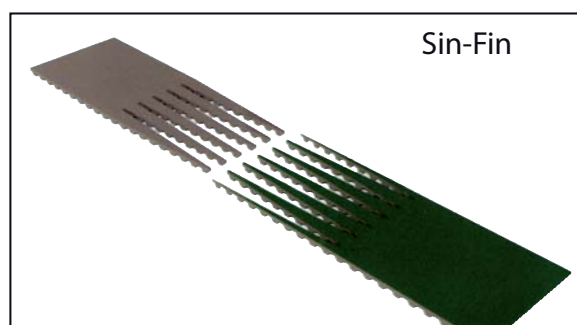
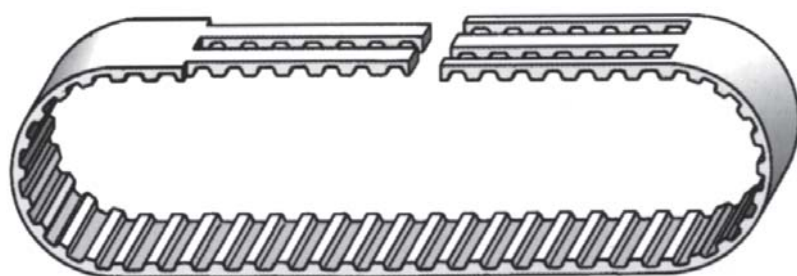

APLICACIONES

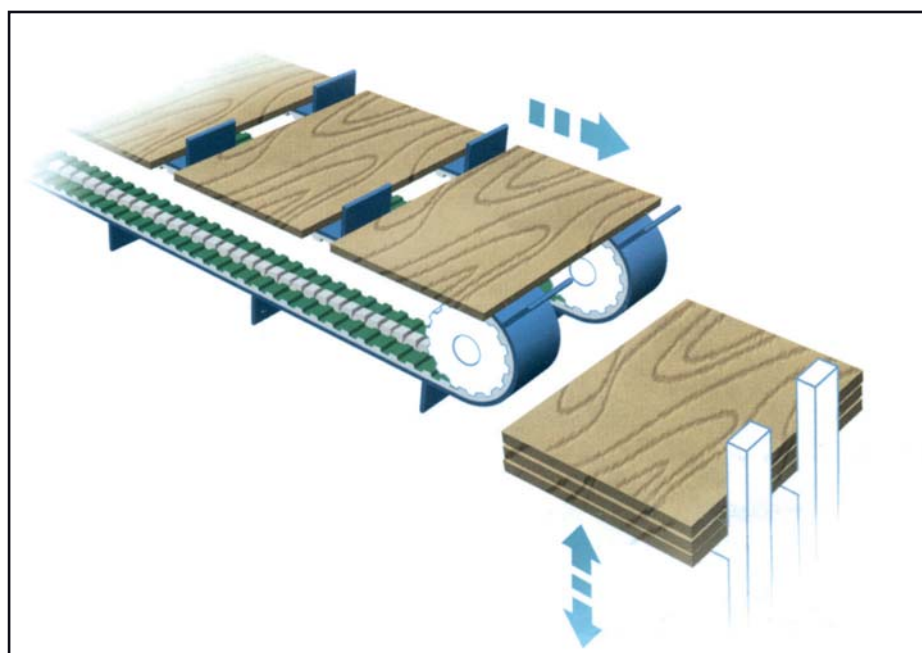

ATLATOS® *Soluciones con tacos, perfiles y dientes*

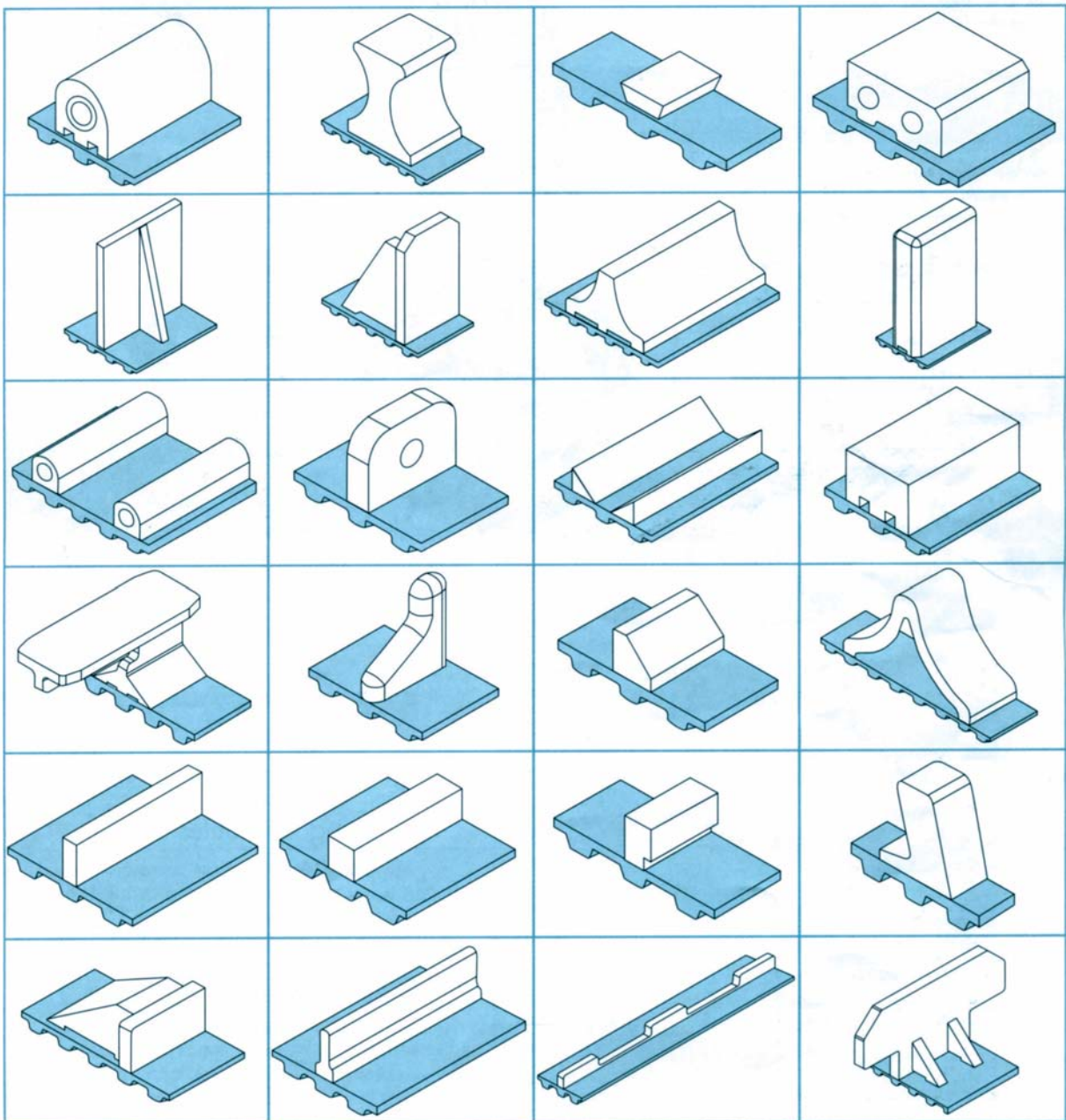
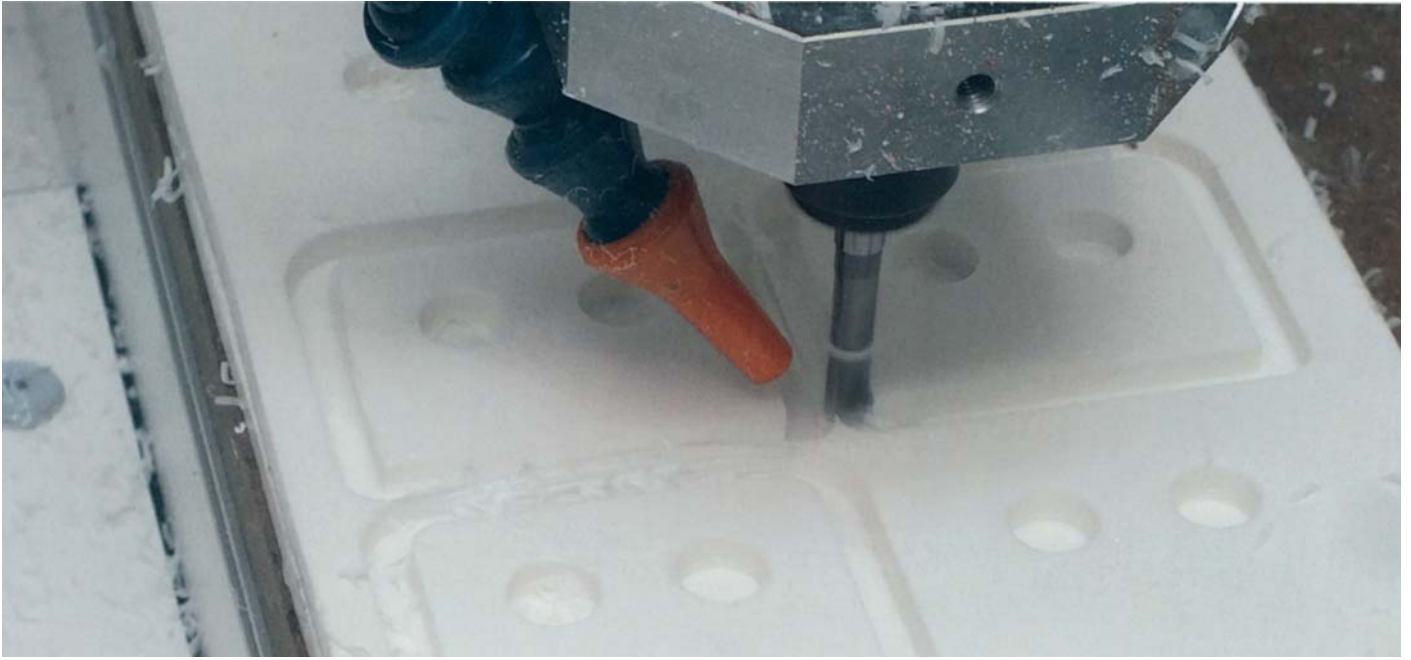

TECNOLOGIA

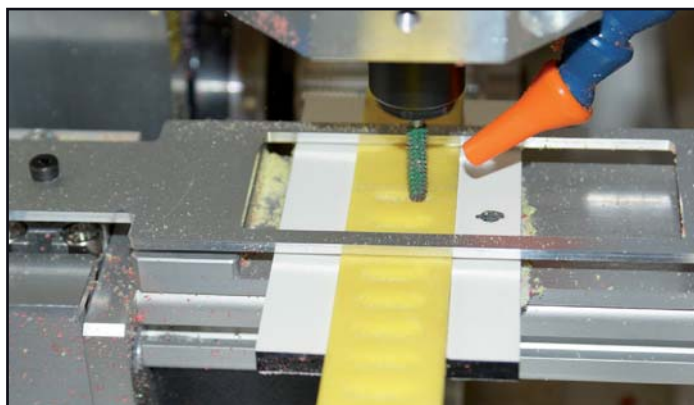
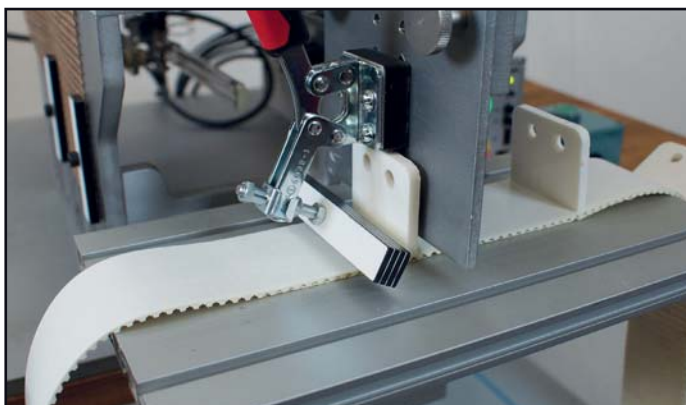

ACABADOS

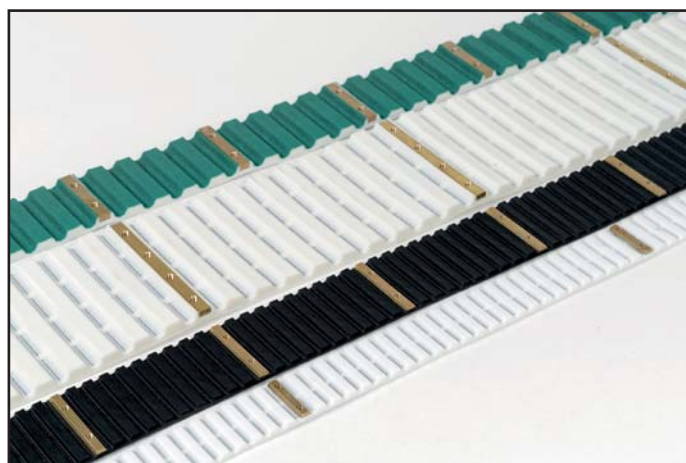
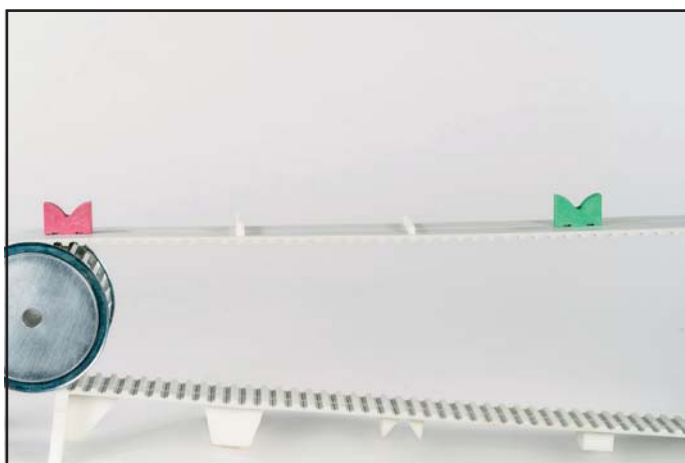

APLICACIONES

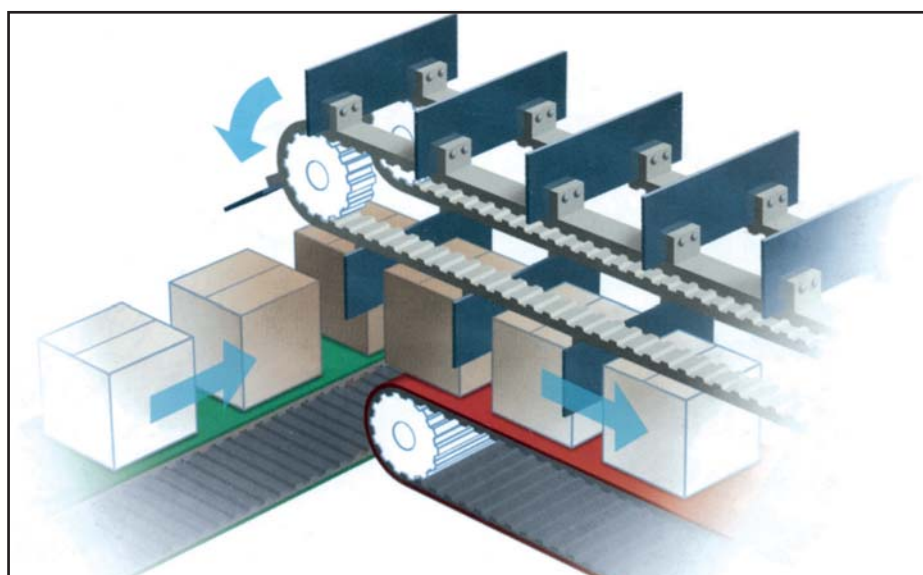

RECUBRIMIENTOS

LINATEX | SYLOMER | CAUCHO | SILICONA | SUPERGRIP PVC | SUPERGRIP CAUCHO
POLIURETANO 85A/75A/52A | GOMA ESPONJOSA | POSIBILIDAD DE RECUBRIR CON OTROS ACABADOS

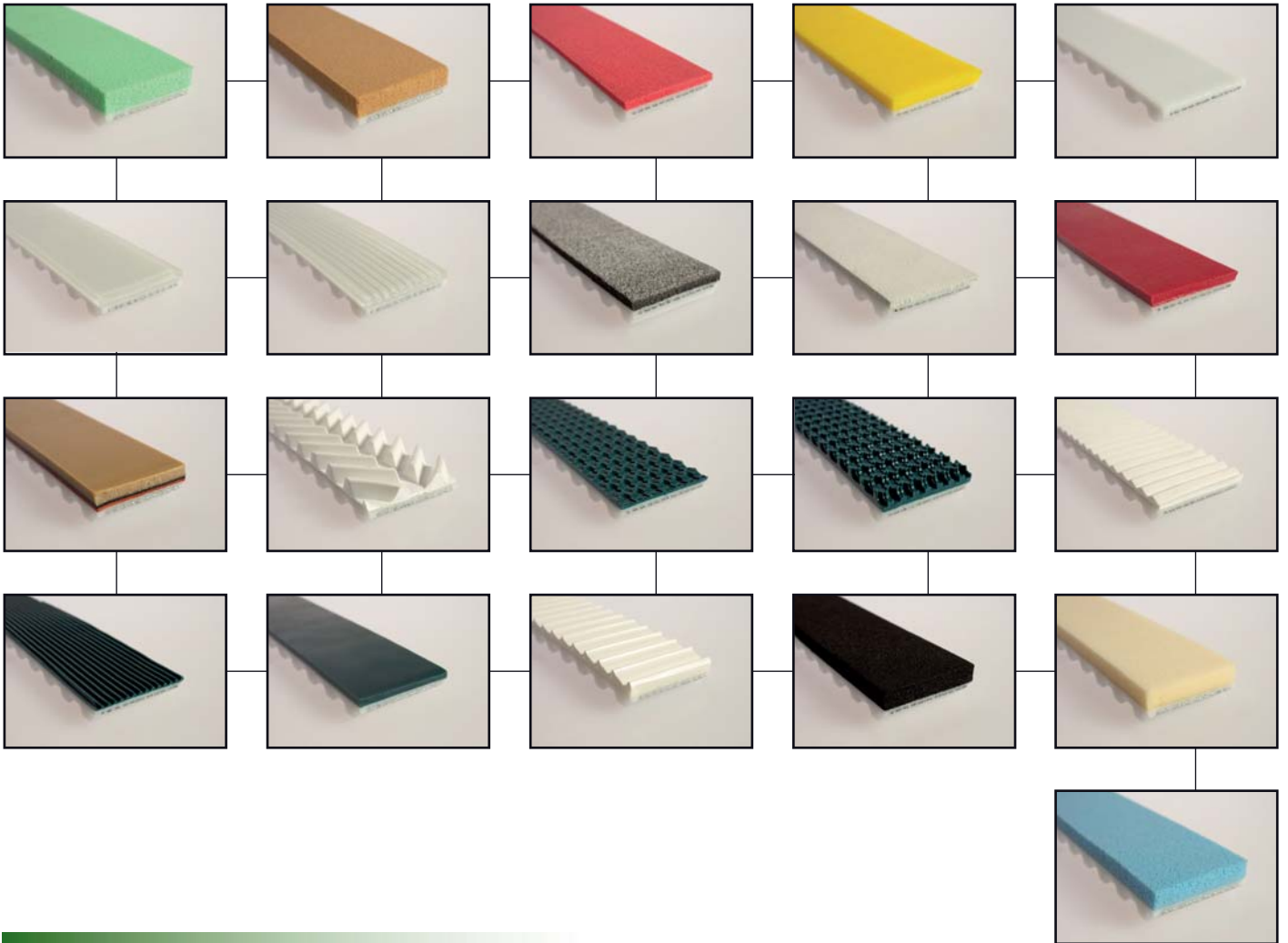

APLICACIONES

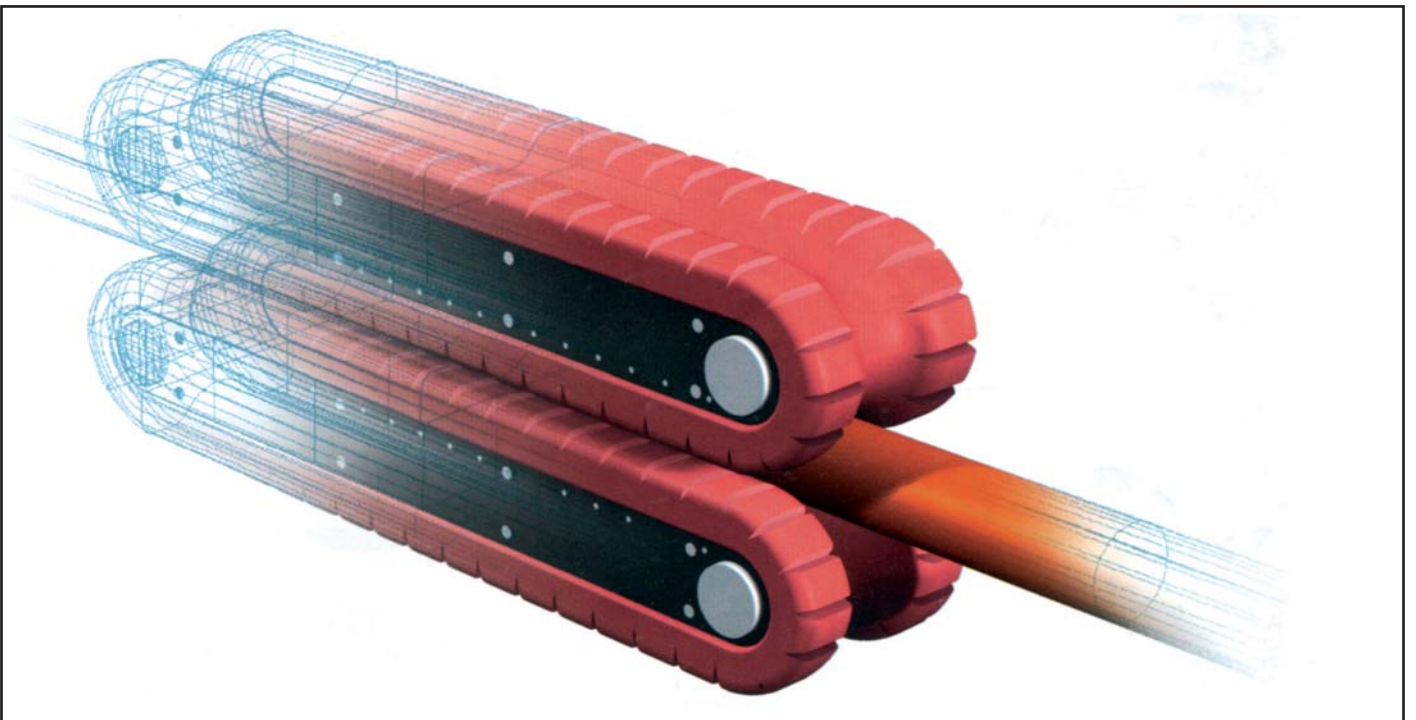

ACABADOS

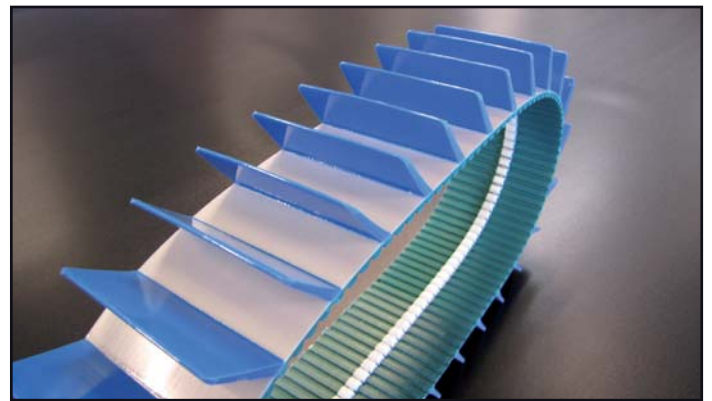
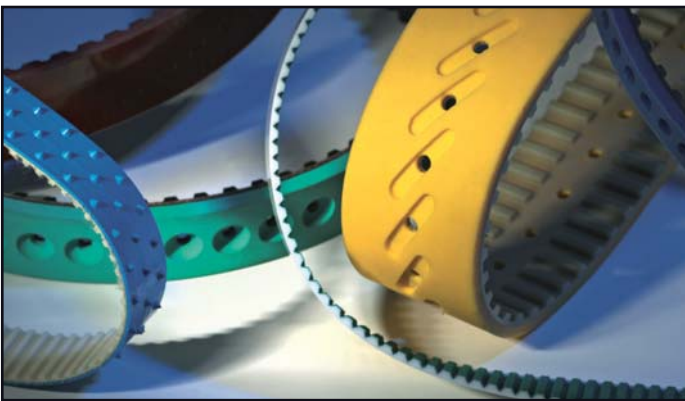
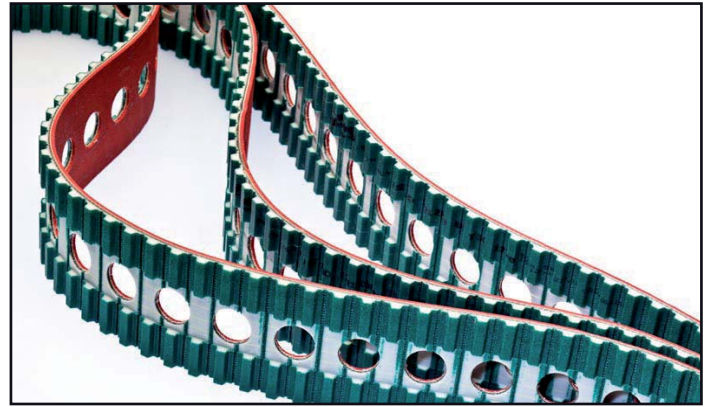

APLICACIONES

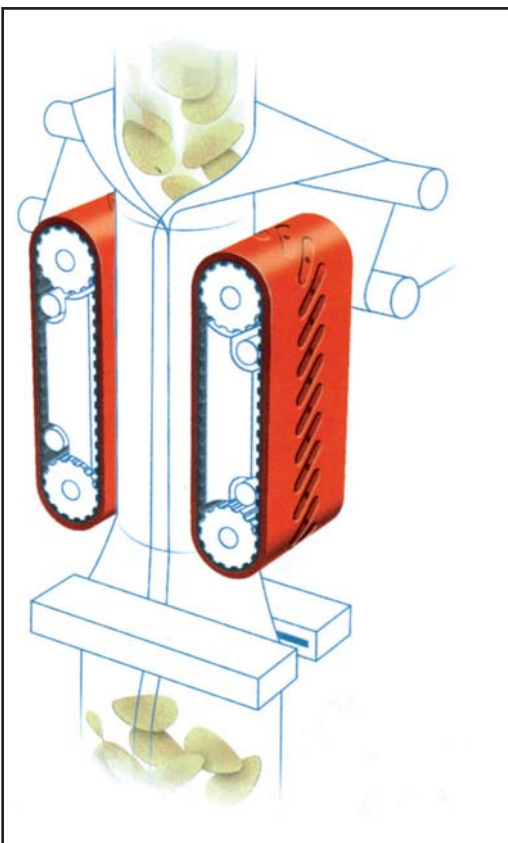

COTAS BÁSICAS PARA LA IDENTIFICACIÓN

